



US006596134B2

(12) **United States Patent**
Forrest et al.

(10) **Patent No.:** **US 6,596,134 B2**
(45) **Date of Patent:** ***Jul. 22, 2003**

(54) **METHOD OF FABRICATING TRANSPARENT CONTACTS FOR ORGANIC DEVICES**

(75) Inventors: **Stephen R. Forrest**, Princeton, NJ (US); **Mark E. Thompson**, Anaheim Hills, CA (US); **Paul E. Burrows**, Princeton, NJ (US); **Vladimir Bulovic**, Metuchen, NJ (US); **Gong Gu**, Princeton, NJ (US)

(73) Assignee: **The Trustees of Princeton University**, Princeton, NJ (US)

(*) Notice: This patent issued on a continued prosecution application filed under 37 CFR 1.53(d), and is subject to the twenty year patent term provisions of 35 U.S.C. 154(a)(2).

Subject to any disclaimer, the term of this patent is extended or adjusted under 35 U.S.C. 154(b) by 0 days.

This patent is subject to a terminal disclaimer.

(21) Appl. No.: **09/468,986**

(22) Filed: **Dec. 21, 1999**

(65) **Prior Publication Data**

US 2002/0153243 A1 Oct. 24, 2002

Related U.S. Application Data

(63) Continuation of application No. 08/872,560, filed on Jun. 10, 1997, now Pat. No. 6,264,805, which is a division of application No. 08/613,207, filed on Mar. 6, 1996, now Pat. No. 5,703,436, which is a continuation-in-part of application No. 08/354,674, filed on Dec. 13, 1994, now Pat. No. 5,707,745.

(51) **Int. Cl.**⁷ **C23C 14/00**; C23C 14/02; B65D 5/06; B65D 5/12

(52) **U.S. Cl.** **204/192.29**; 204/192.26; 427/68; 427/69; 427/70; 427/255.6

(58) **Field of Search** 204/192.26, 192.27, 204/192.28, 192.29; 427/585, 68, 69, 70, 75, 78, 525, 529, 531, 255.6

(56) **References Cited**

U.S. PATENT DOCUMENTS

3,261,844 A 7/1966 Trofimenko

(List continued on next page.)

FOREIGN PATENT DOCUMENTS

EP 0 715 803 10/1997

(List continued on next page.)

OTHER PUBLICATIONS

R.H. Partridge, "Electroluminescence from polyvinylcarbazole films: 3. Electroluminescent devices", *Polymer*, vol. 24, pp. 748-754, Jun. 1983.*

(List continued on next page.)

Primary Examiner—Patrick Ryan

Assistant Examiner—Julian A. Mercado

(74) *Attorney, Agent, or Firm*—Kenyon & Kenyon

(57) **ABSTRACT**

A multicolor organic light emitting device employs vertically stacked layers of double heterostructure devices which are fabricated from organic compounds. The vertical stacked structure is formed on a glass base having a transparent coating of ITO or similar metal to provide a substrate. Deposited on the substrate is the vertical stacked arrangement of three double heterostructure devices, each fabricated from a suitable organic material. Stacking is implemented such that the double heterostructure with the longest wavelength is on the top of the stack. This constitutes the device emitting red light on the top with the device having the shortest wavelength, namely, the device emitting blue light, on the bottom of the stack. Located between the red and blue device structures is the green device structure. The devices are configured as stacked to provide a staircase profile whereby each device is separated from the other by a thin transparent conductive contact layer to enable light emanating from each of the devices to pass through the semitransparent contacts and through the lower device structures while further enabling each of the devices to receive a selective bias. The devices are substantially transparent when de-energized, making them useful for heads-up display applications.

89 Claims, 25 Drawing Sheets

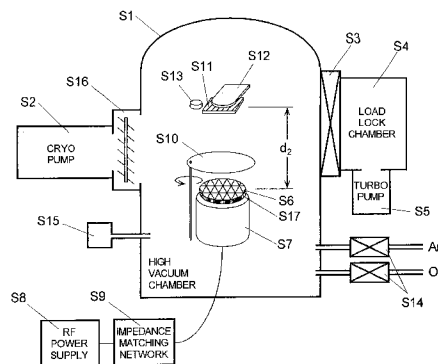

U.S. PATENT DOCUMENTS

3,611,069	A	10/1971	Galginitis et al.			
3,681,381	A	8/1972	Trofimenko			
3,783,353	A	1/1974	Pankove			
3,840,873	A	10/1974	Usui			
3,875,456	A	4/1975	Kano et al.			
4,020,389	A	4/1977	Dickson et al.			
4,281,053	A	7/1981	Tang et al.			
4,291,815	A	9/1981	Gordon et al.			
4,298,769	A	11/1981	Richman			
4,365,260	A	12/1982	Holonyak, Jr.			
4,558,171	A	12/1985	Gantley et al.			
4,577,207	A	3/1986	Copeland			
4,605,942	A	8/1986	Camlibel et al.			
4,693,777	A	9/1987	Hazano et al.			
4,720,432	A	1/1988	VanSlyke et al.	428/457		
4,769,292	A	9/1988	Tang et al.			
4,777,402	A	10/1988	Mitsumori			
4,791,075	A	12/1988	Lin			
4,885,211	A	12/1989	Tang et al.			
4,900,584	A	2/1990	Tuenge et al.			
4,950,950	A	8/1990	Perry et al.			
5,047,687	A	9/1991	VanSlyke			
5,059,861	A	10/1991	Littman			
5,064,782	A	11/1991	Nishiguchi			
5,075,743	A	12/1991	Behfar-Rad			
5,077,588	A	12/1991	Yamada			
5,084,650	A	1/1992	Ryu			
5,118,986	A	6/1992	Ohnuma et al.			
5,144,473	A	9/1992	Gemma et al.			
5,150,006	A	9/1992	VanSlyke et al.			
5,166,761	A	11/1992	Olson et al.			
5,216,331	A	6/1993	Hosokawa et al.			
5,231,049	A	7/1993	Neugebauer et al.			
5,276,380	A	1/1994	Tang			
5,286,296	A	* 2/1994	Sato et al.	118/719		
5,294,869	A	3/1994	Tang et al.			
5,294,870	A	3/1994	Tang et al.			
5,315,129	A	5/1994	Forrest et al.			
5,324,604	A	6/1994	Bugner et al.			
5,329,540	A	7/1994	Lee et al.			
5,343,050	A	8/1994	Egusa et al.			
5,352,543	A	10/1994	Ryu			
5,391,896	A	2/1995	Wanlass			
5,405,709	A	4/1995	Littman et al.			
5,405,710	A	4/1995	Dodabalapur et al.			
5,409,783	A	4/1995	Tang et al.			
5,416,494	A	5/1995	Yokota et al.			
5,424,560	A	* 6/1995	Norman et al.	257/40		
5,427,858	A	6/1995	Nakamura et al.			
5,429,884	A	7/1995	Namiki et al.			
5,449,432	A	9/1995	Hanawa			
5,449,564	A	9/1995	Nishio et al.			
5,456,988	A	10/1995	Sano et al.			
5,457,565	A	10/1995	Namiki et al.			
5,478,658	A	12/1995	Dodabalapur et al.			
5,486,406	A	1/1996	Shi			
5,505,985	A	* 4/1996	Nakamura et al.	427/66		
5,540,999	A	7/1996	Yamamoto et al.			
5,552,547	A	9/1996	Shi			
5,578,379	A	11/1996	Stutzmann et al.			
5,583,350	A	12/1996	Norman et al.			
5,598,059	A	1/1997	Sun et al.			
5,601,903	A	2/1997	Fujii et al.			
5,604,398	A	2/1997	Zyung et al.			
5,617,445	A	4/1997	Jewell et al.			
5,629,530	A	5/1997	Brown et al.			
5,641,611	A	6/1997	Shieh et al.			
5,663,573	A	9/1997	Epstein et al.			
5,672,938	A	9/1997	Jones			
5,703,436	A	12/1997	Forrest et al.			
5,707,745	A	1/1998	Forrest et al.			
5,719,467	A	2/1998	Antoniadis et al.			
5,755,938	A	5/1998	Fukui et al.			
5,757,139	A	5/1998	Forrest et al.			
5,821,160	A	10/1998	Martens et al.			
5,821,690	A	10/1998	Martens et al.			
5,834,130	A	11/1998	Kido et al.			
5,834,893	A	11/1998	Bulovic et al.			
5,881,089	A	3/1999	Berggren et al.			
5,917,280	A	6/1999	Barrows et al.			
5,981,306	A	* 11/1999	Burrows et al.	438/22		
5,994,835	A	11/1999	Wilson et al.			

FOREIGN PATENT DOCUMENTS

JP	55-41707	3/1980
JP	59-56391	* 3/1984
JP	62-295090	12/1987
JP	63-75783	4/1988
JP	63-264692	* 11/1988
JP	1-225092	* 9/1989
JP	2-8290	* 1/1990
JP	2-56892	2/1990
JP	2-168593	6/1990
JP	3-93736	* 4/1991
JP	3-187192	* 8/1991
JP	3-210790	9/1991
JP	3-233892	10/1991
JP	3-107861	11/1991
JP	3-250583	11/1991
JP	4-137485	* 5/1992
JP	4-278983	10/1992
JP	3-214593	9/1993
JP	5-331460	* 12/1993
JP	6-1972	* 1/1994
JP	6-33050	* 2/1994
JP	6-68977	* 3/1994
JP	693256	* 4/1994
JP	6-172751	* 6/1994
JP	6-212153	* 8/1994
JP	6-283267	* 10/1994
JP	6-290873	10/1994
JP	6-302383	* 10/1994
JP	7-57873	* 3/1995
WO	95/06400	3/1995
WO	96/19792	6/1996

OTHER PUBLICATIONS

Chen and Shi, "Metal Chelates as emitting materials for organic electroluminescence," *Coord. Chem. Rev.*, v.171 (May 1998) pp. 161-174.

Hoshino, et al., "Electroluminescence from triplet excited states of benzophenone," *Appl. Phys. Lett.*, v.69(2) (Jul. 1996) pp. 224-226.

Shoustikov, et al., "Orange and red light-emitting devices . . .," *Synth. Met.*, v.91(1-3) (May 1997) pp. 217-221.

Frescura, et al., "Large High-Density Monolithic . . .," *IEEE Transactions on Electron Devices*, vol. ED-24, No. 7 (Jul. 1977) pp. 891-898.

Trofimenko, *J. Amer. Chem. Soc.*, v.89 (1967) pp. 6288-6294.

C.W. Tang, et al., "Organic Electroluminescent Diodes", 51 *Appl. Phys. Lett.*, 913 (1987).

K.L. Chopra et al., "Transparent Conductors—A Status Review", *Thin Solid Films*, vol. 102 (1983).

T. Karasawa et al., "Electrical and Optical Properties of Indium Tin Oxide Thin Films Deposited on Unheated Substrates by D.C. Reactive Sputtering", *Thin Solid Films*, vol. 223 (1993).

S.B. Lee et al., "Electronic and Optical Properties of Room Temperature Sputter Deposited Indium Tin Oxide", *J. Vac. Sci. Technol. A*, 11(5), Sep./Oct. 1993.

S. Honda et al., "Oxygen Content of Indium Tin Oxide Films Fabricated by Reactive Sputtering", *J. Vac. Sci. Technol. A*, 13(3), May/June. 1995.

- K. Sreenivas et al., "Preparation and Characterization of RF Sputtered Indium Tin Oxide Films", *J. Appl. Phys.*, 57(2), Jan. 15, 1985.
- L.R. Gilbert et al., "Comparison of ITO Sputtering Process from a Ceramic and Alloy Targets onto Room Temperature PET Substrates", *Society for Vacuum Pauters*, 36 Conf. Proc., 1993, p. 236.
- Y. Hamada et al., "Blue Electroluminescence in Thin Films of Azomethin-Zinc Complexes", *Japanese Journal of Applied Physics*, 1993, vol. 32, pp. L511-513.
- J. Kido et al., "Organic Electroluminescent Devices Using Lanthanide Complexes", *Journal of Alloys and Compounds*, 1993, vol. 192, pp. 30-33.
- C.E. Johnson, et al., "Luminescent Iridium (I), Rhodium (R), and Platinum (II) Dithiolate Complexes", *Journal of the American Chemical Society*, 1983, vol. 105, pp. 1795-1802.
- S.W. Depp et al., "Flat Panel Displays", *Scientific American*, Mar. 1993, pp. 90-97.
- P.E. Burrows et al., "Metal Ion Dependent Luminescence Effects in Metal Tris-Quinolate Organic Heterojunction Light Emitting Devices", *Appl. Phys. Lett.*, 64 p. 2718 (1994).
- N. Takada et al., "Strongly Directed Emission from Controlled-Spontaneous-Emission electroluminescent Diodes with Europium complex as an Emitter", *Japanese J. Appl. Phys.*, p. 33, L863 (1994).
- C. Adachi et al., "Blue Light Emitting Organic Electroluminescent Devices", *Appl. Phys. Lett.*, 56, p. 799 (1990).
- P.E. Burrows et al., "Electroluminescence from Trap-Limited current Transport in Vacuum Deposited Organic Light Emitting Devices", *Appl. Phys. Lett.*, 64, p. 2285 (1993).
- D.Z. Garbuzov et al., "Photoluminescence Efficiency and Adsorption of Aluminum-Tris-Quinolate (Alq₃) Thin Films", *Chem. Phys. Lett.*, (1996).

* cited by examiner

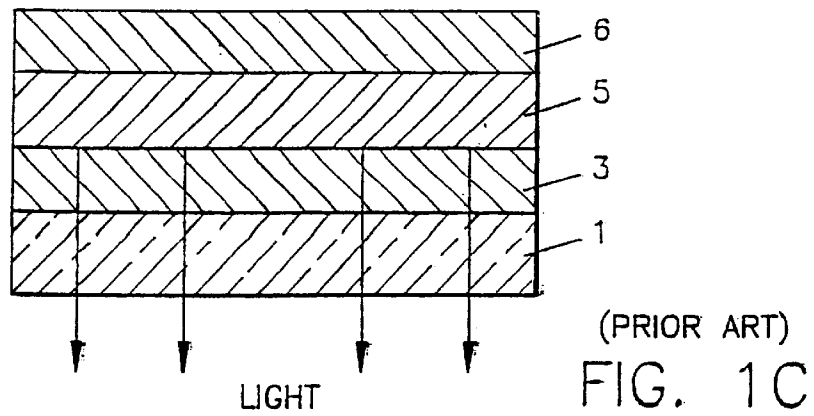
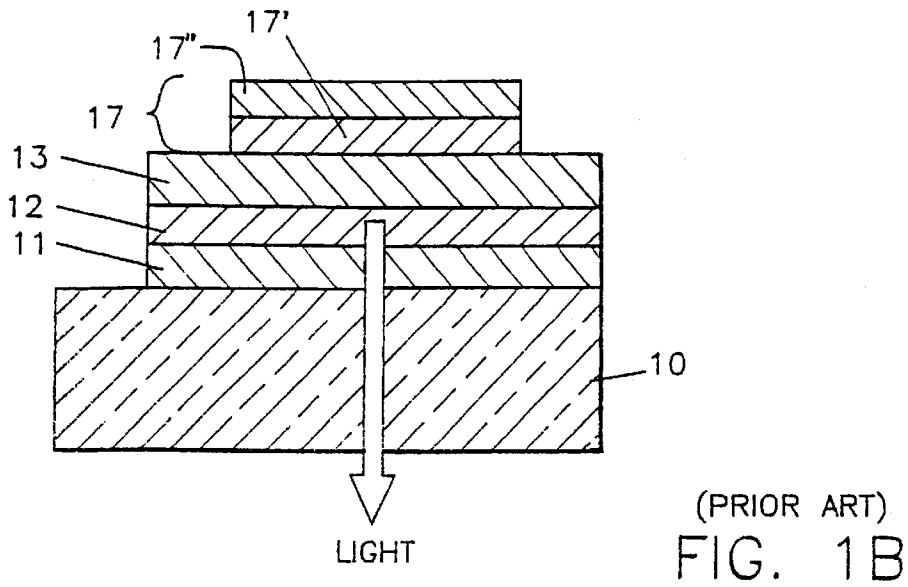
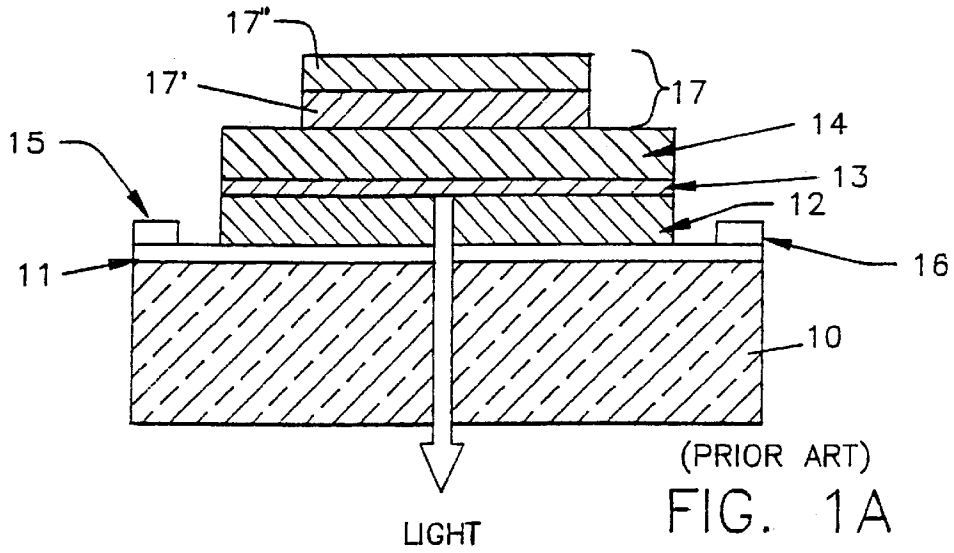

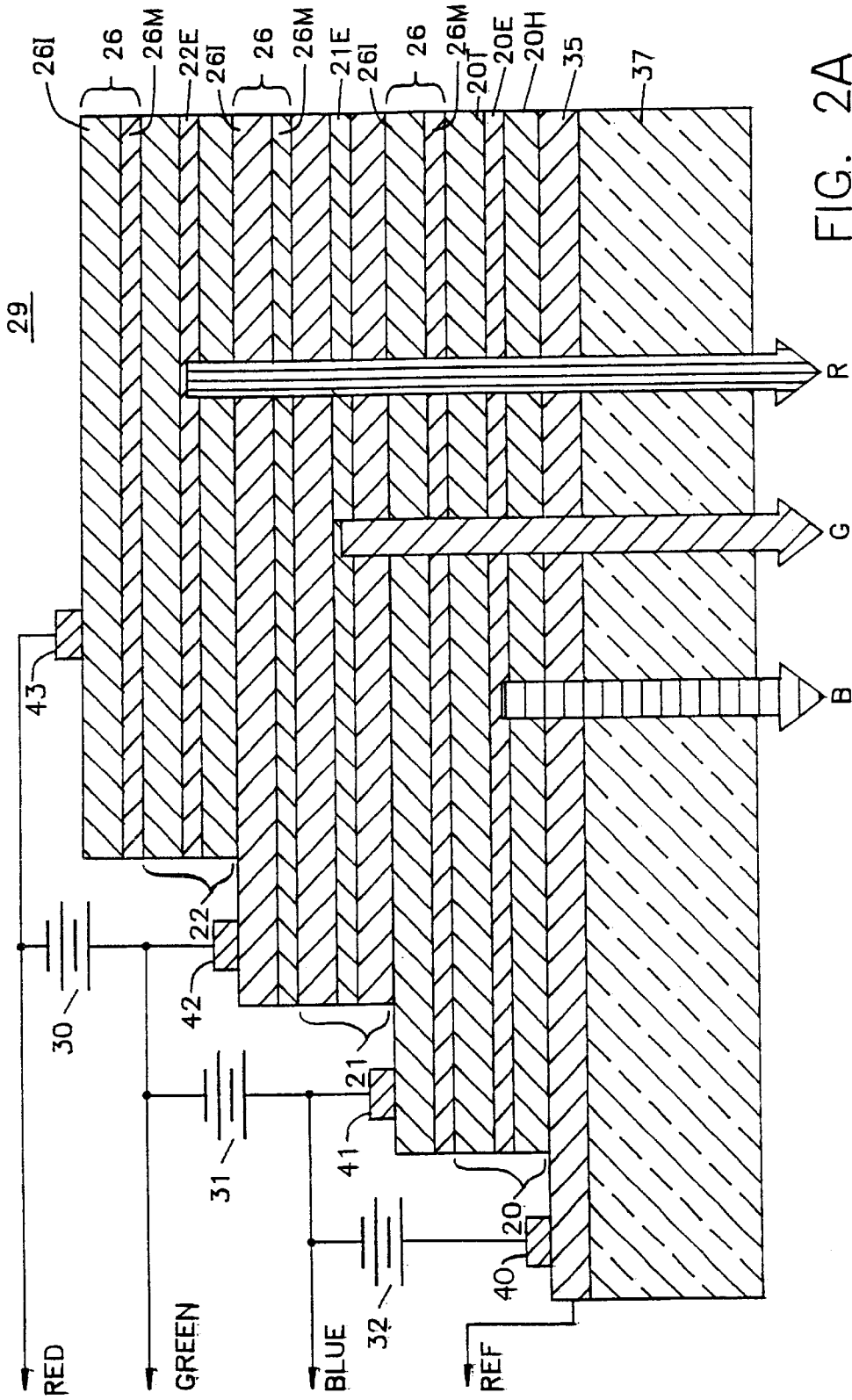

FIG. 2A

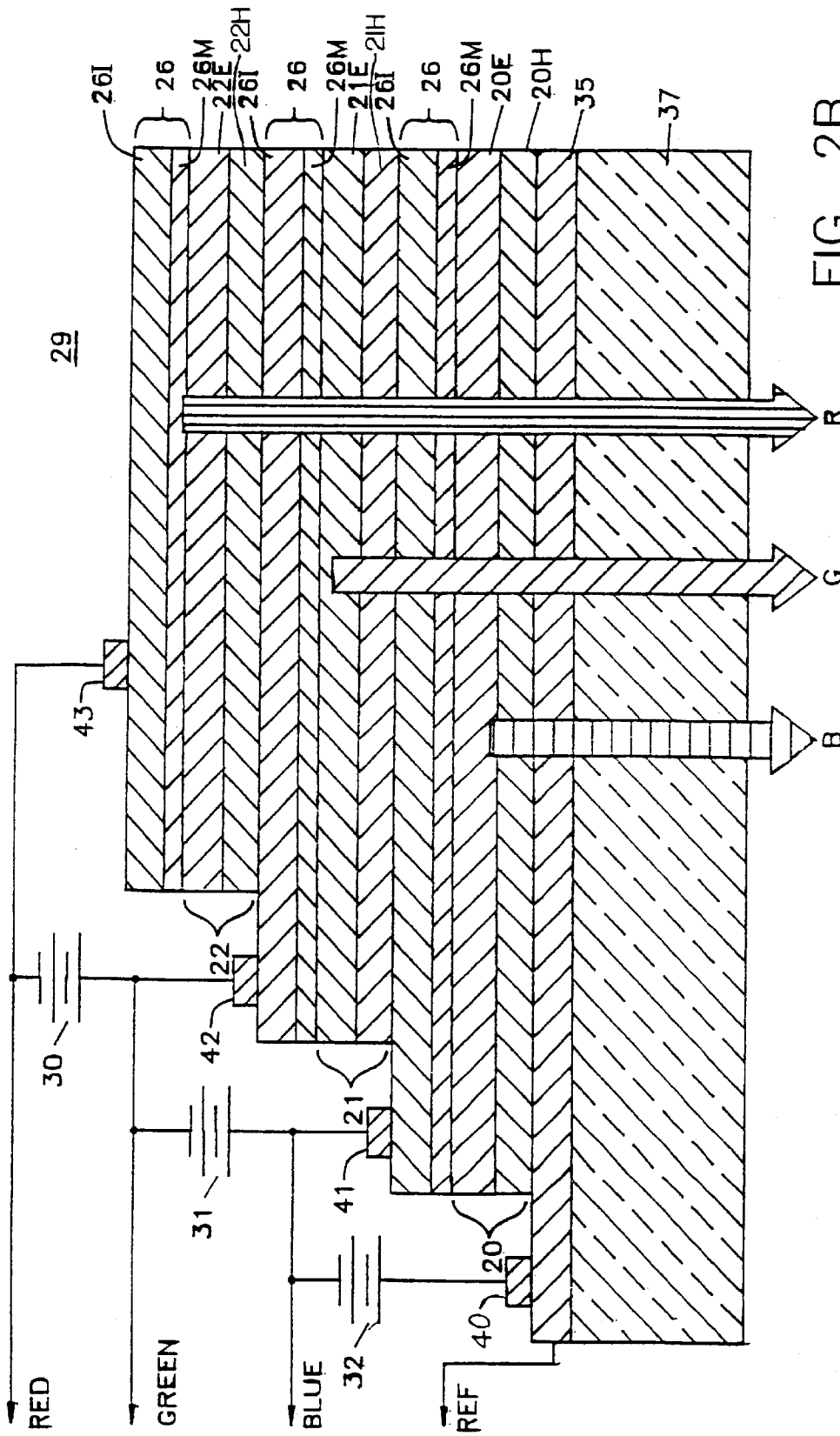

FIG. 2B

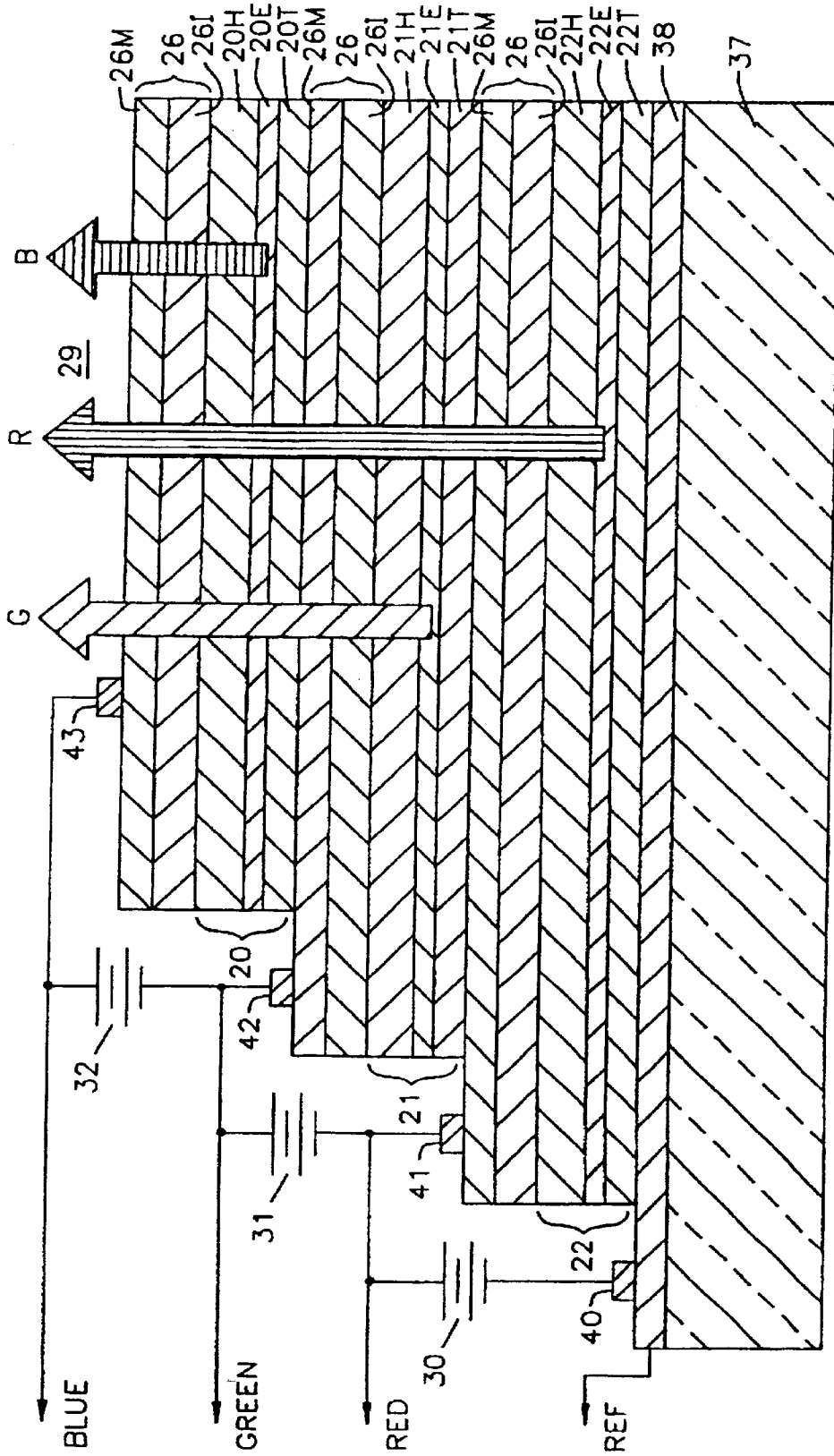

FIG. 2C

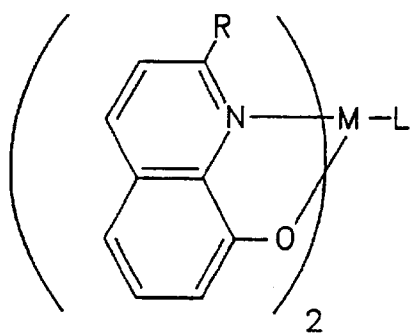

FIG. 3

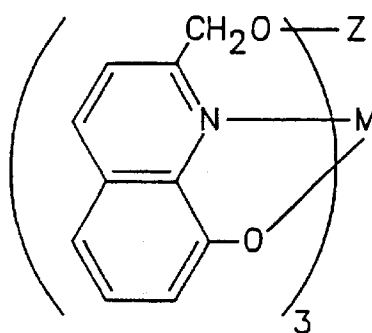

FIG. 4A

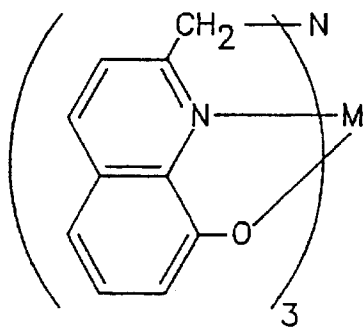

FIG. 4B

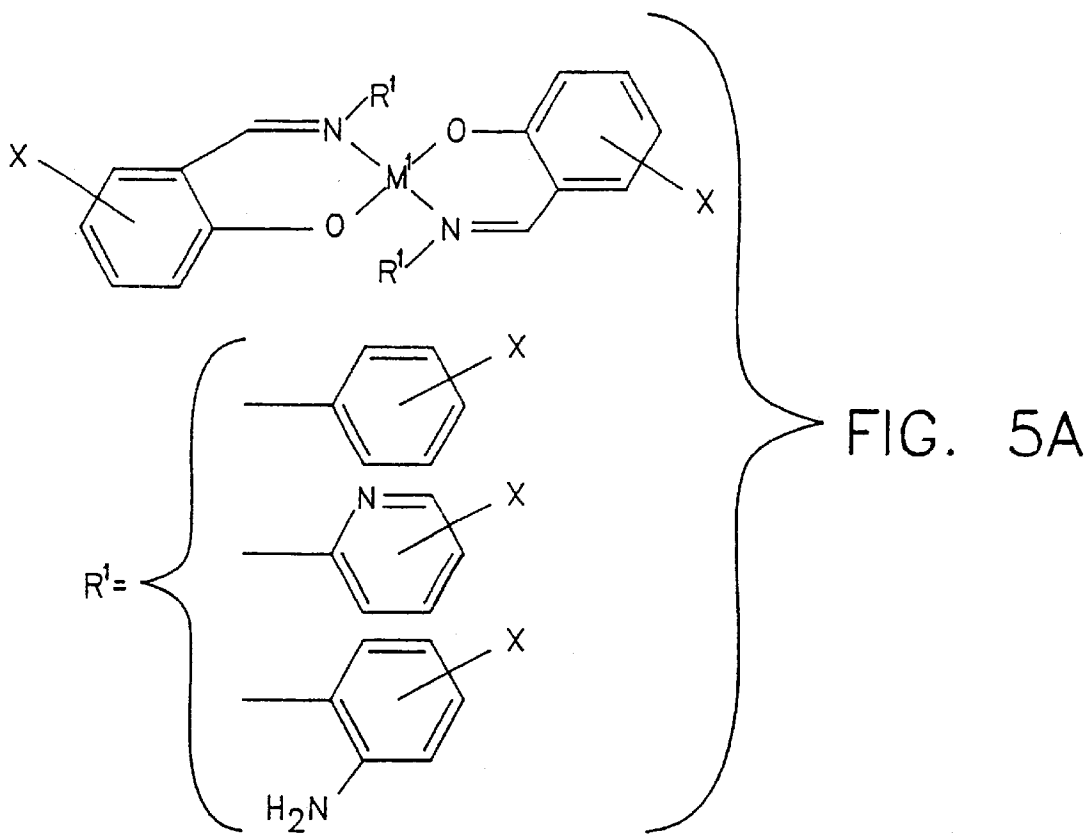

FIG. 5A

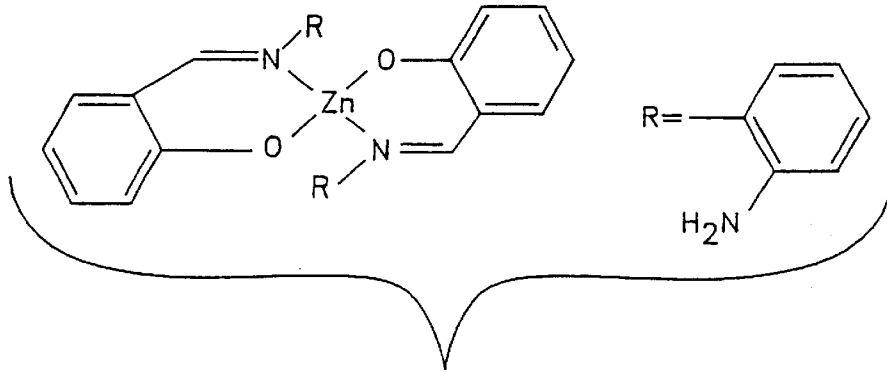

FIG. 5B

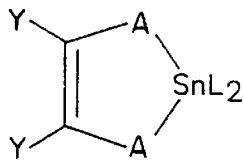

FIG. 6

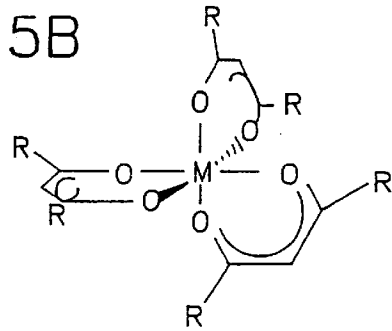
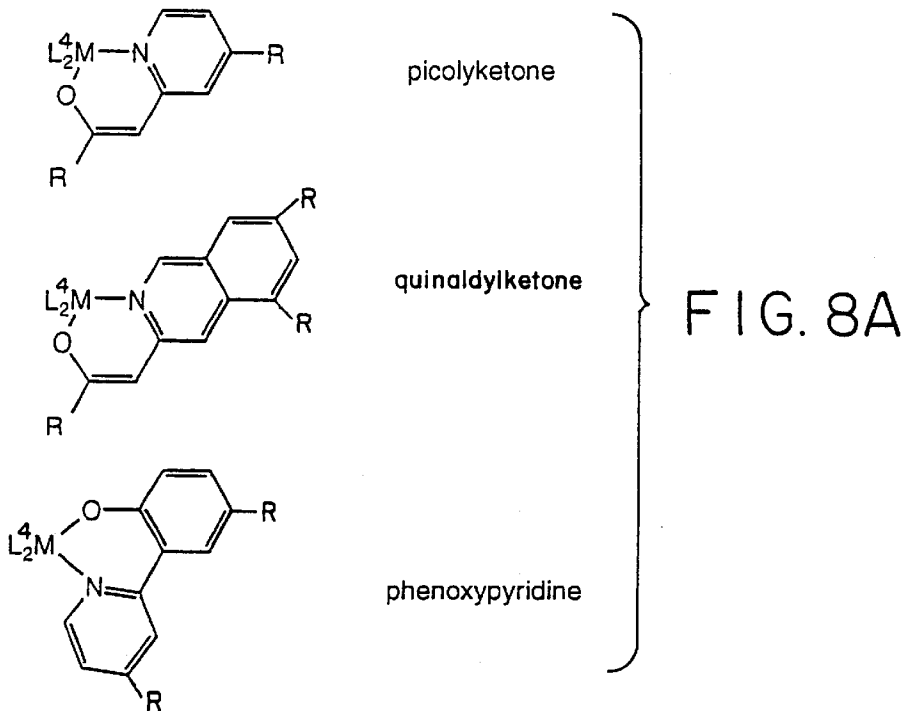

FIG. 7



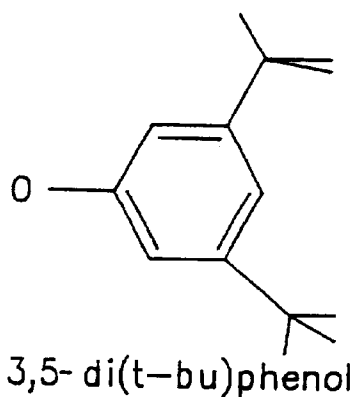

FIG. 8B

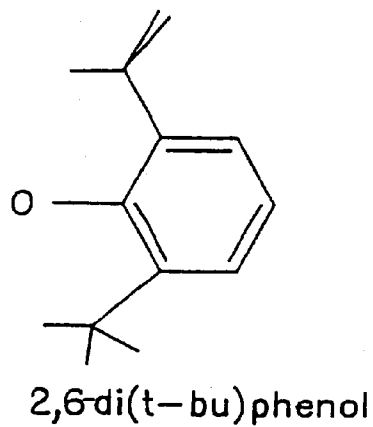

FIG. 8C

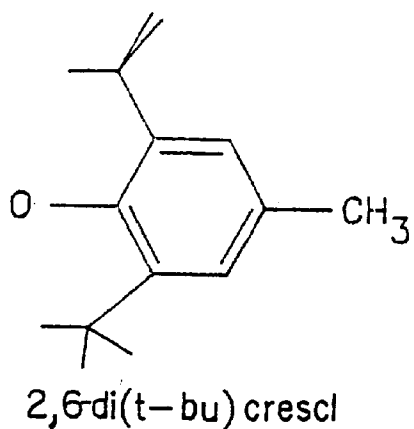

FIG. 8D

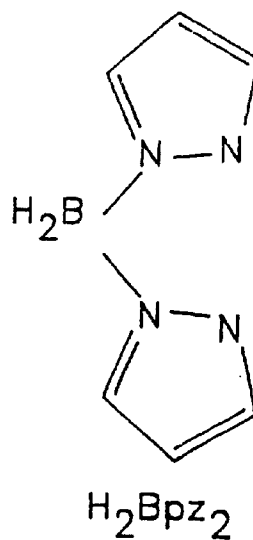

FIG. 8E

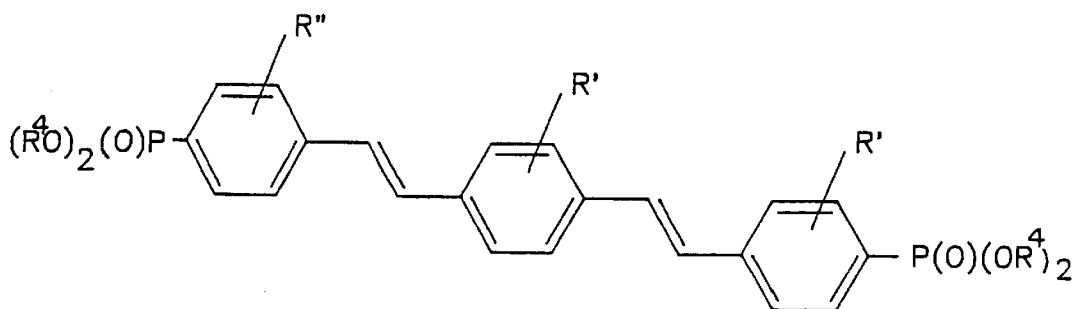

FIG. 9A

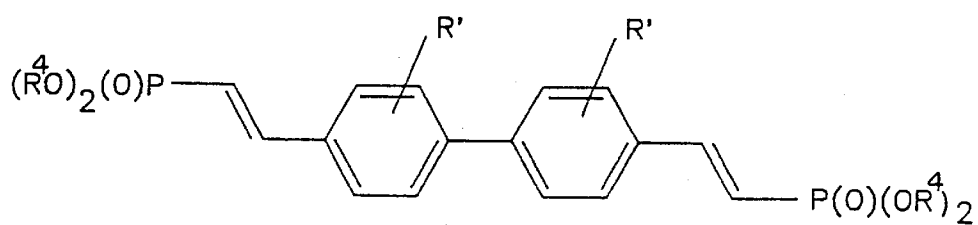

FIG. 9B

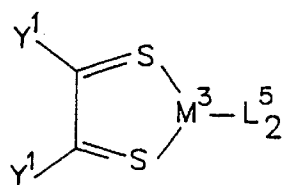

FIG. 10

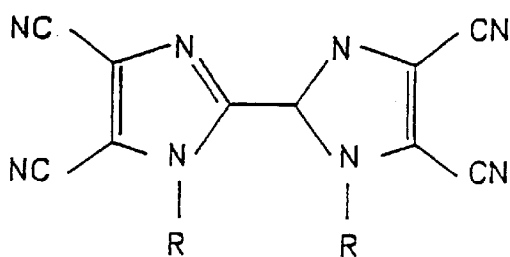

FIG. 11A

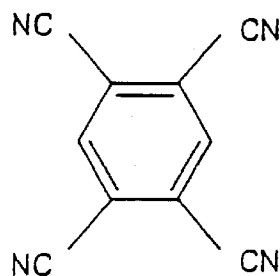

FIG. 11B

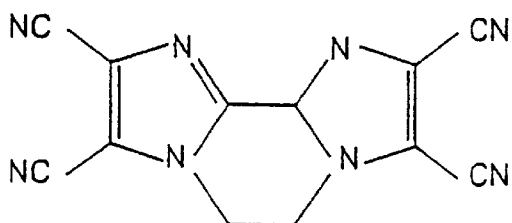

FIG. 11C

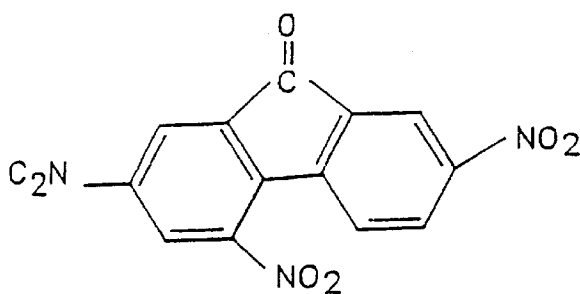

FIG. 11D

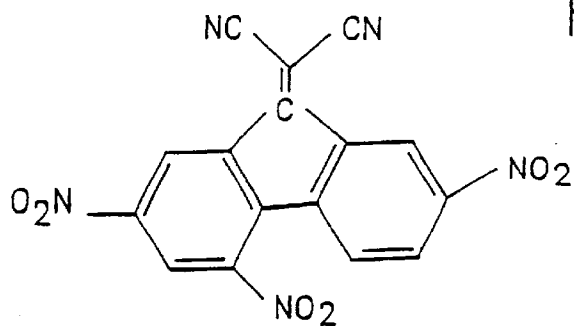

FIG. 11E

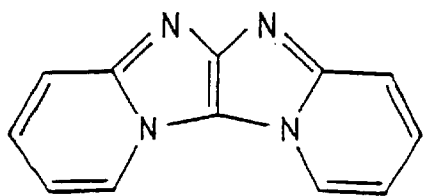

FIG. 11F

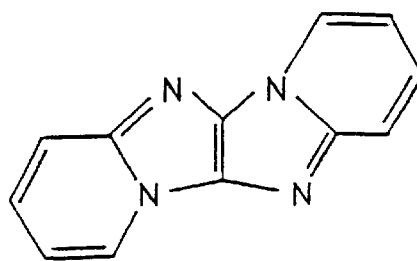

FIG. 11G

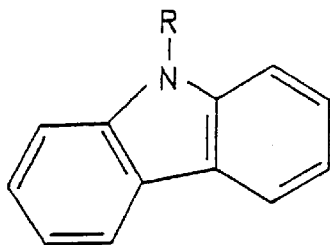

FIG. 11H

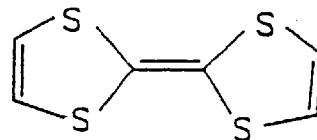

FIG. 11I

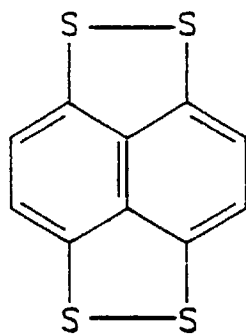

FIG. 11J

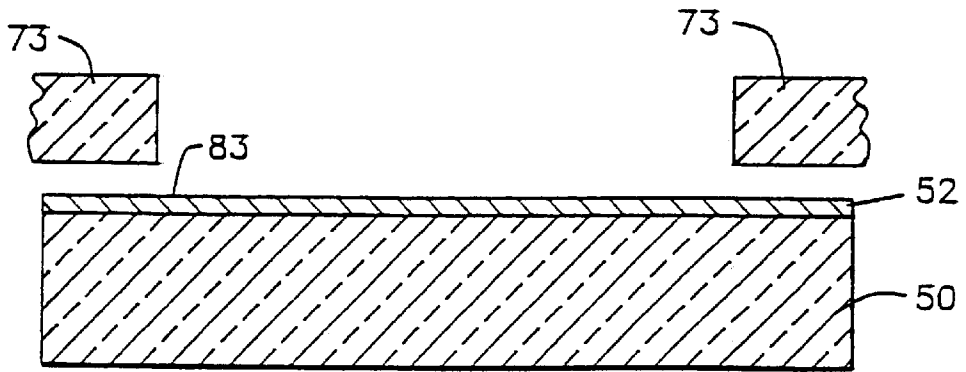

FIG. 12A

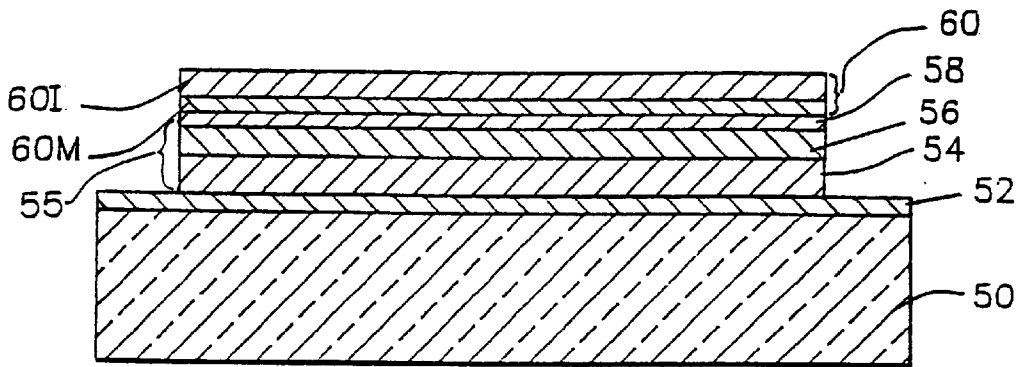

FIG. 12B

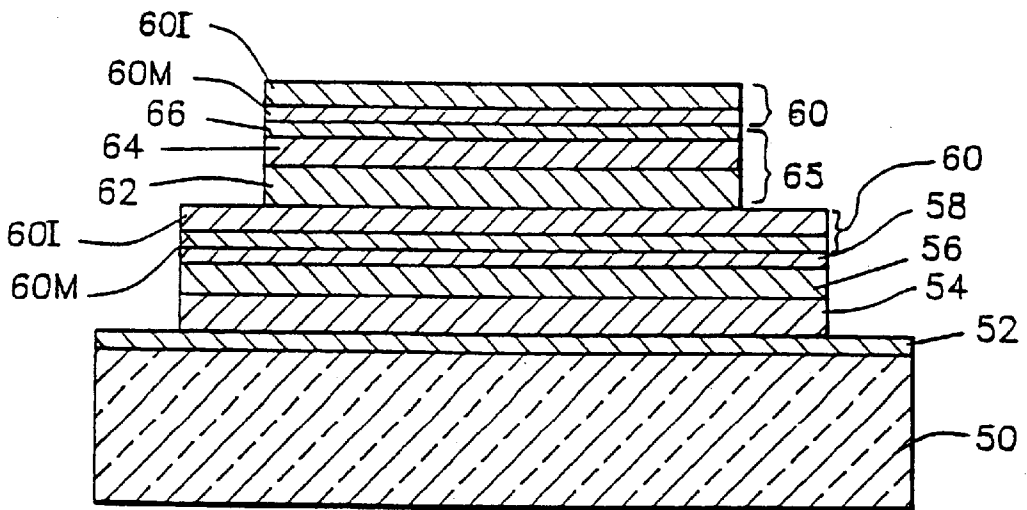

FIG. 12C

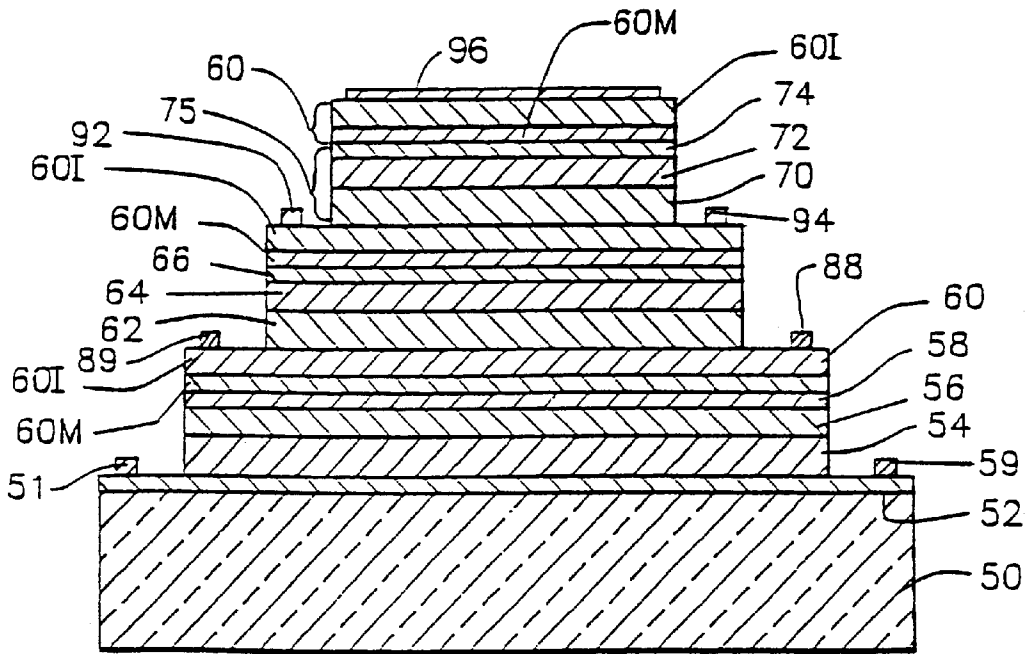

FIG. 12D

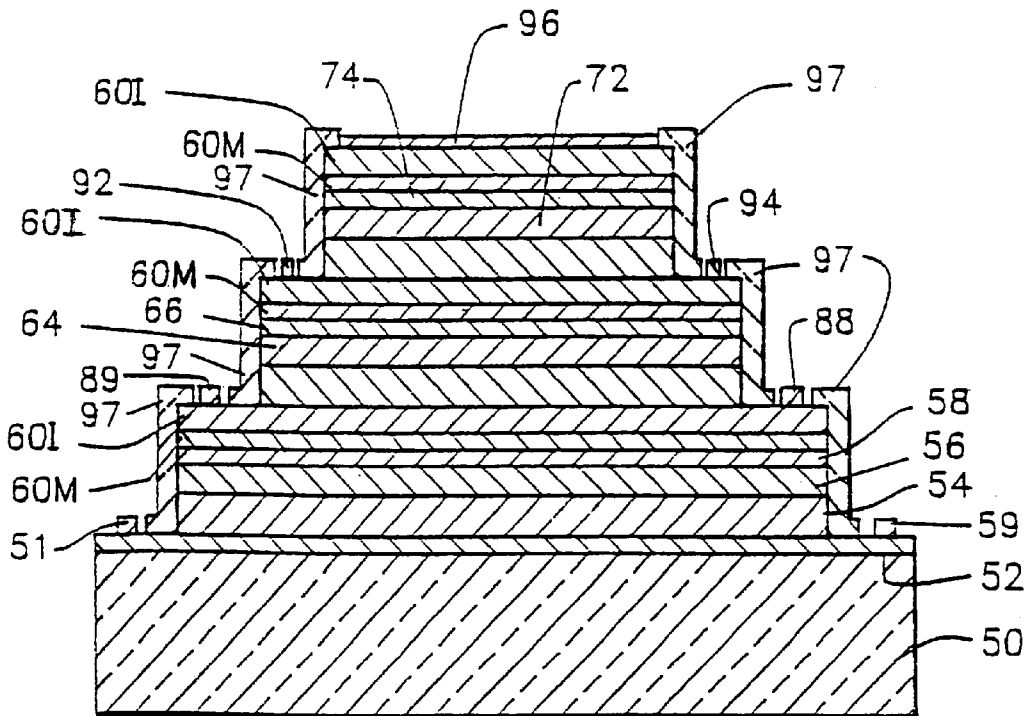

FIG. 12E

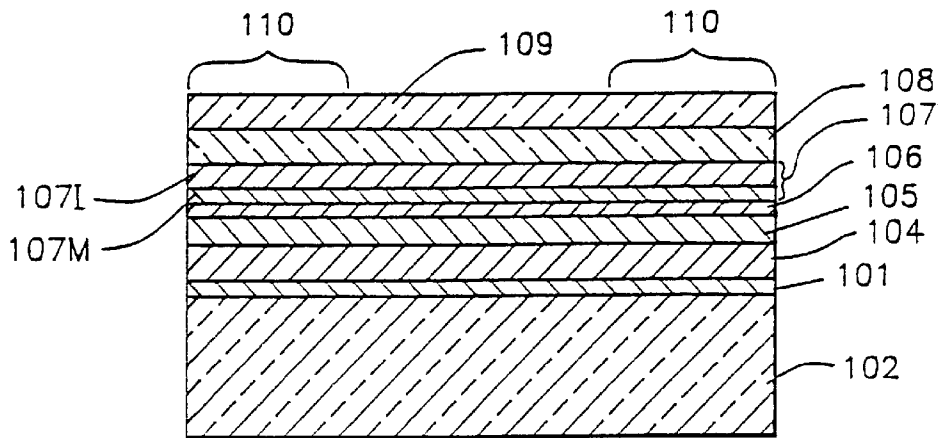

FIG. 13A

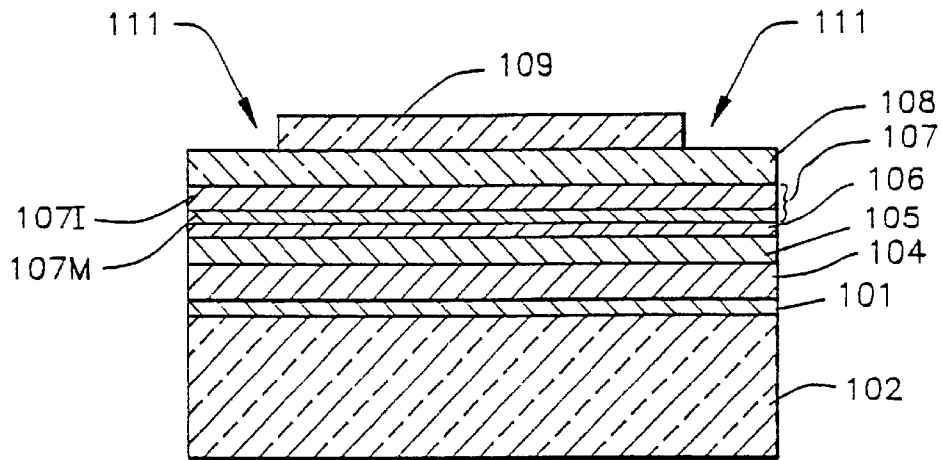

FIG. 13B

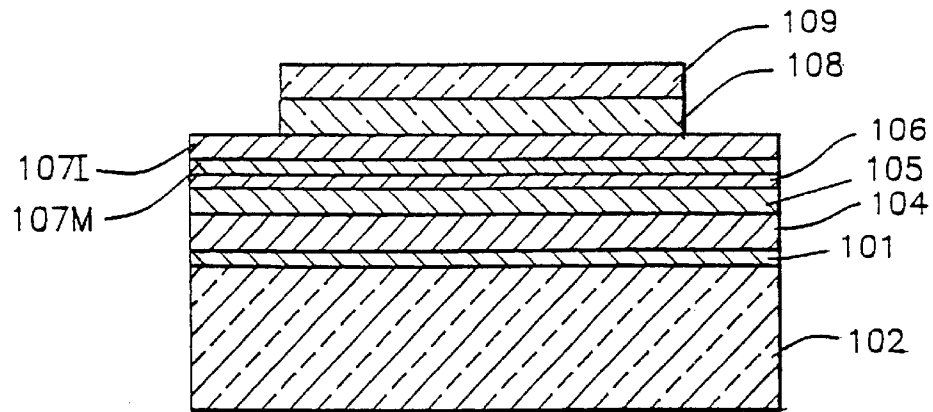

FIG. 13C

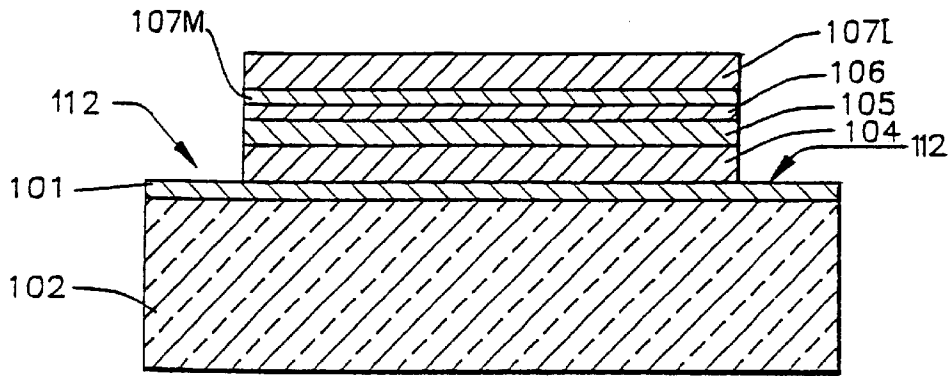

FIG. 13D

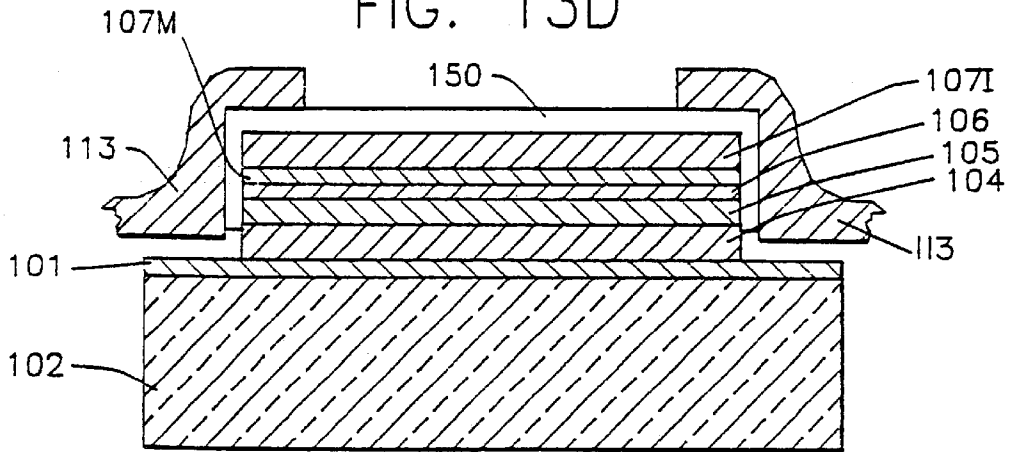

FIG. 13E

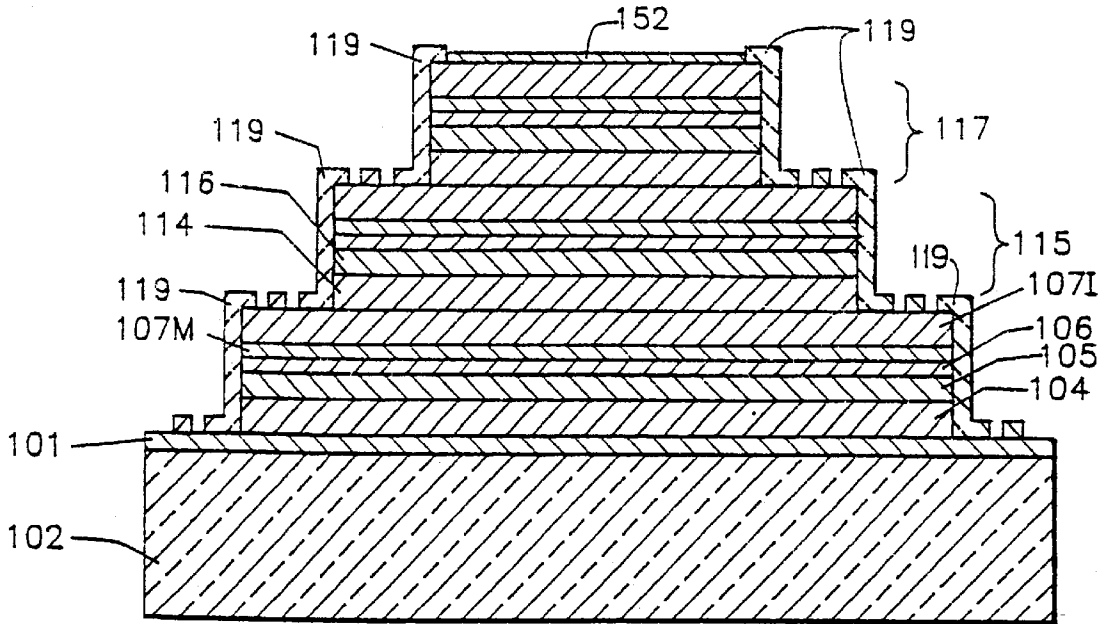

FIG. 13F

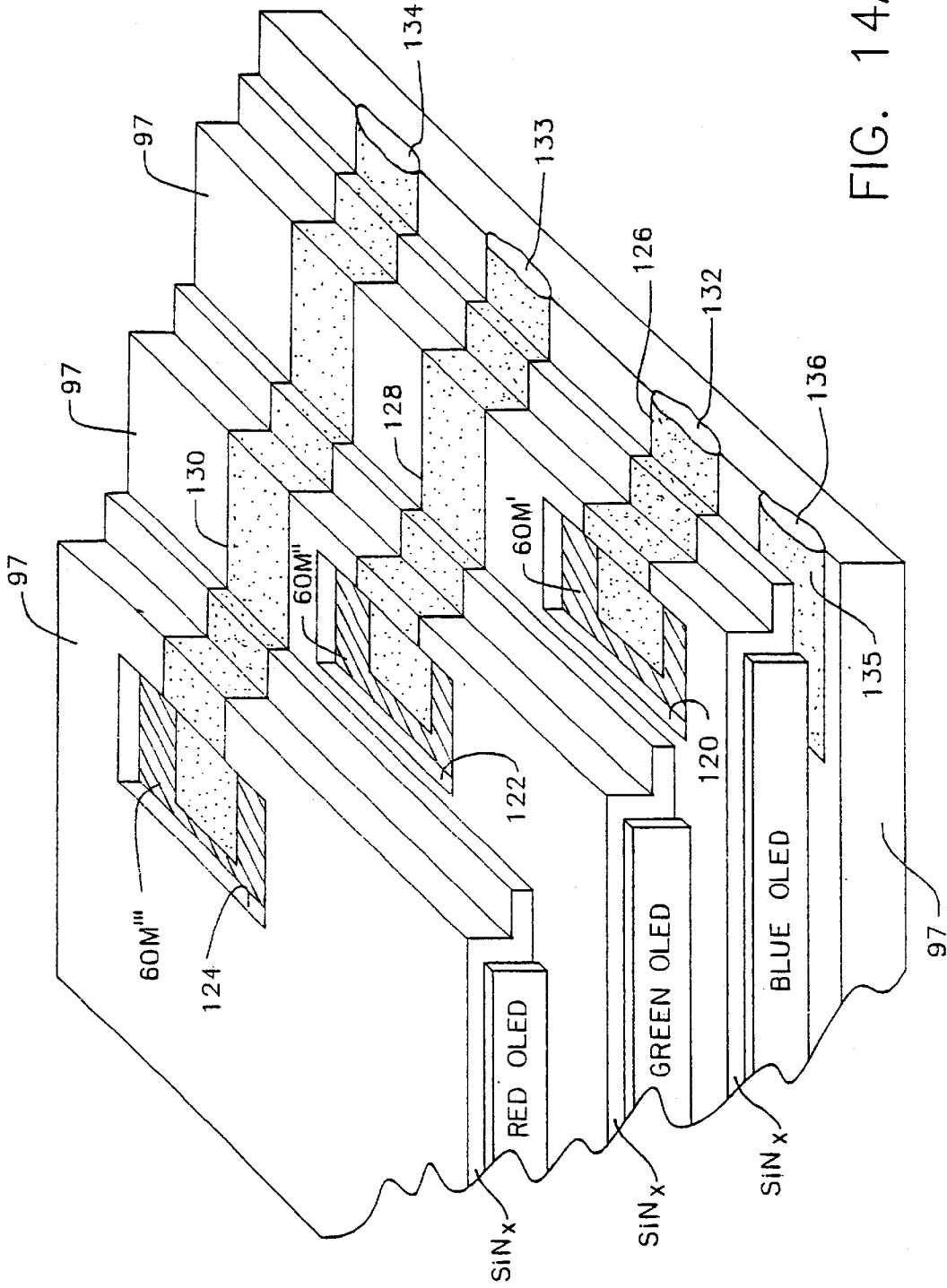

FIG. 14A

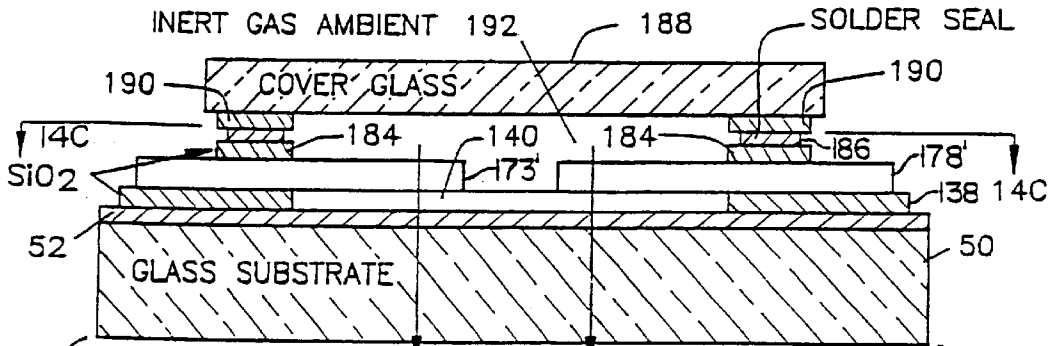

FIG. 14B

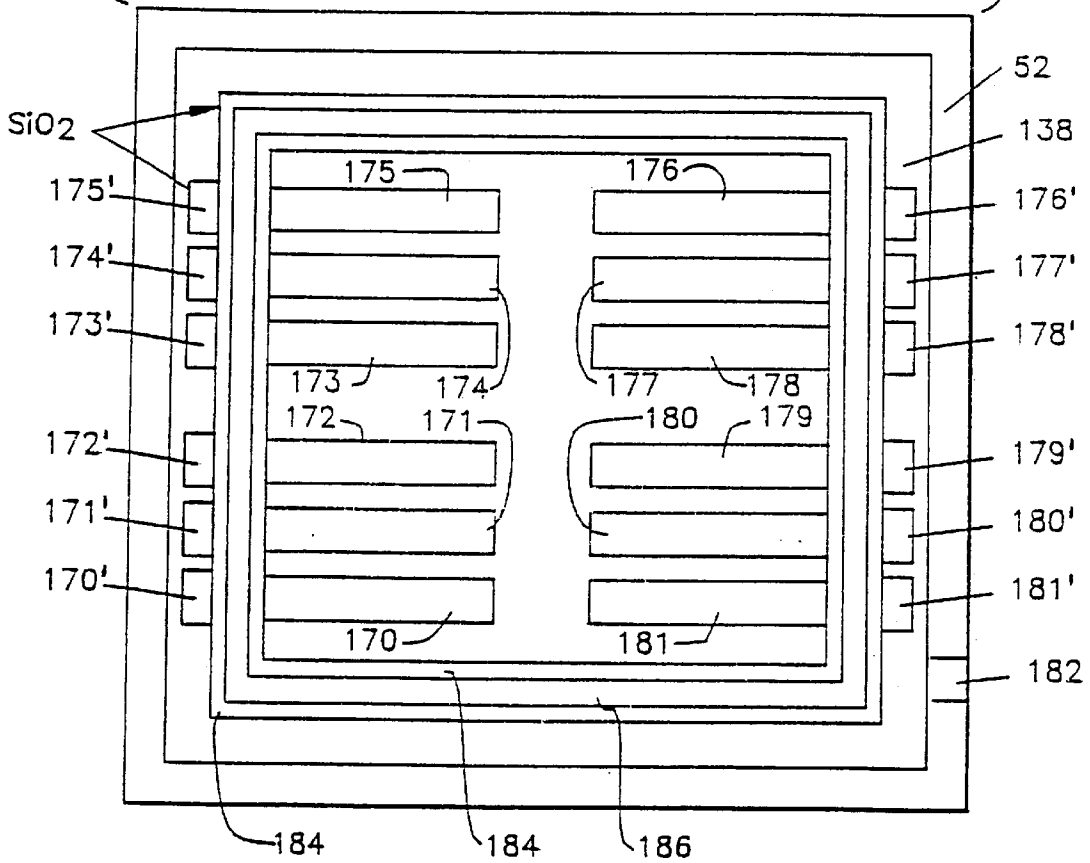
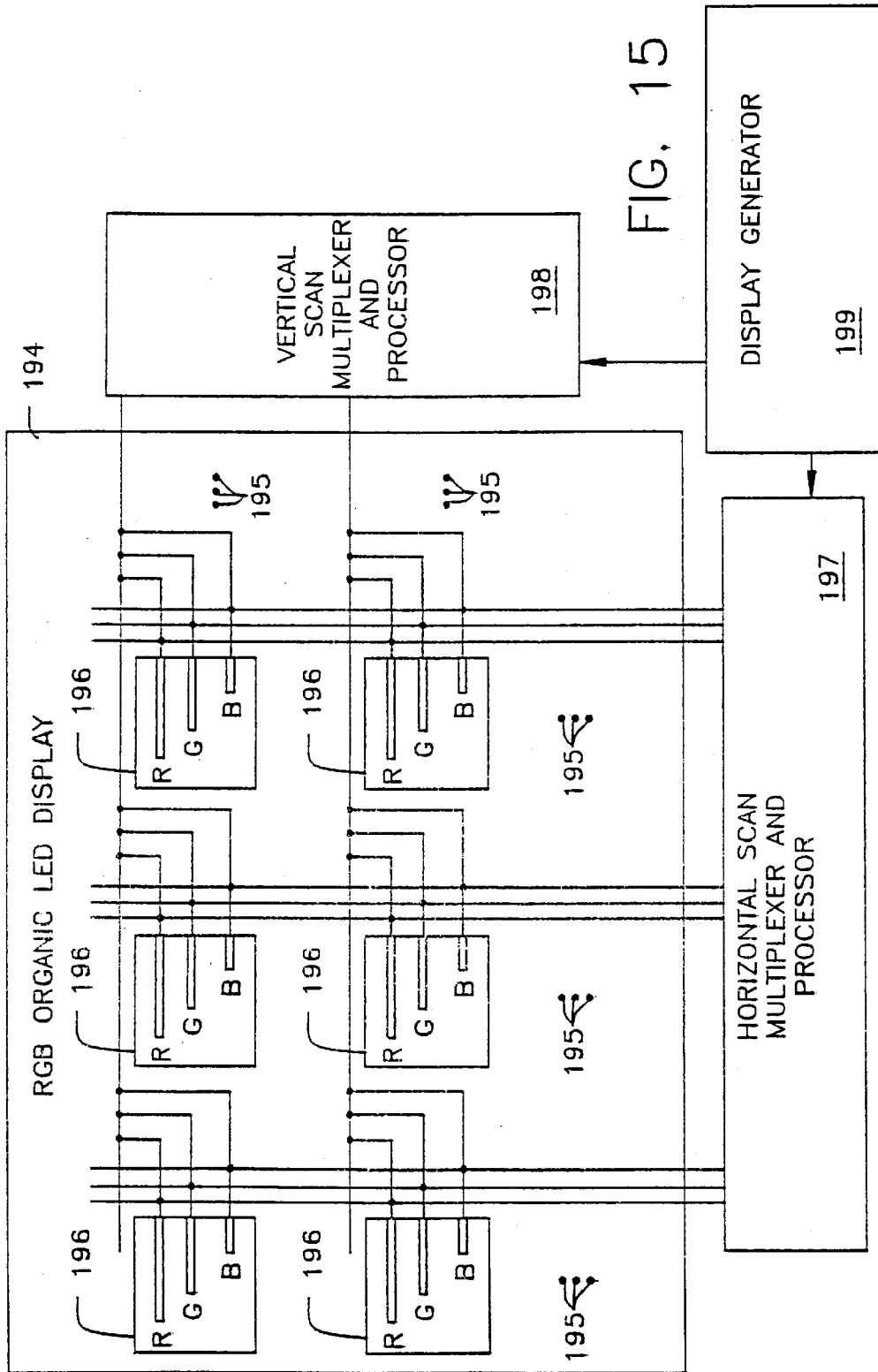

FIG. 14C



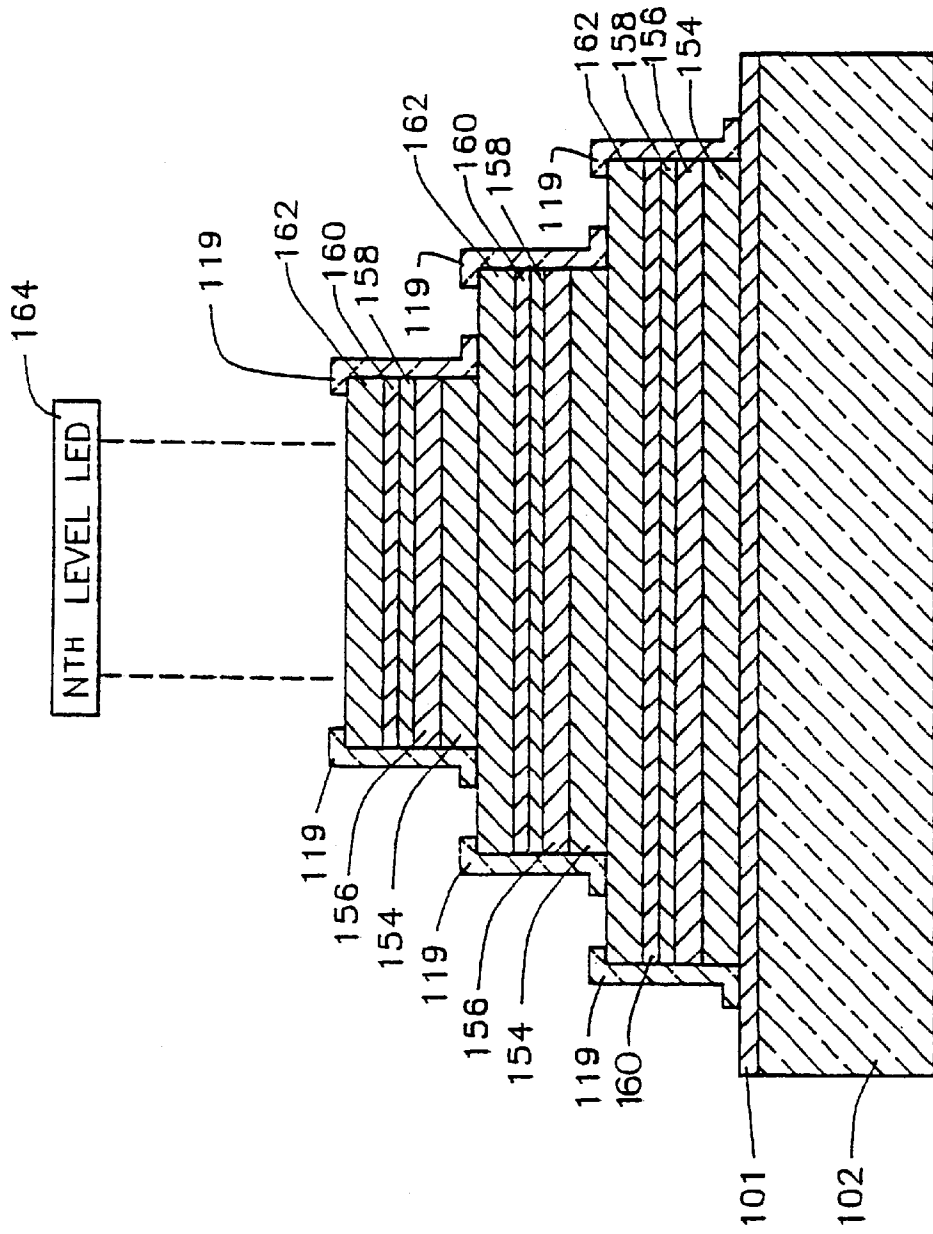

FIG. 16

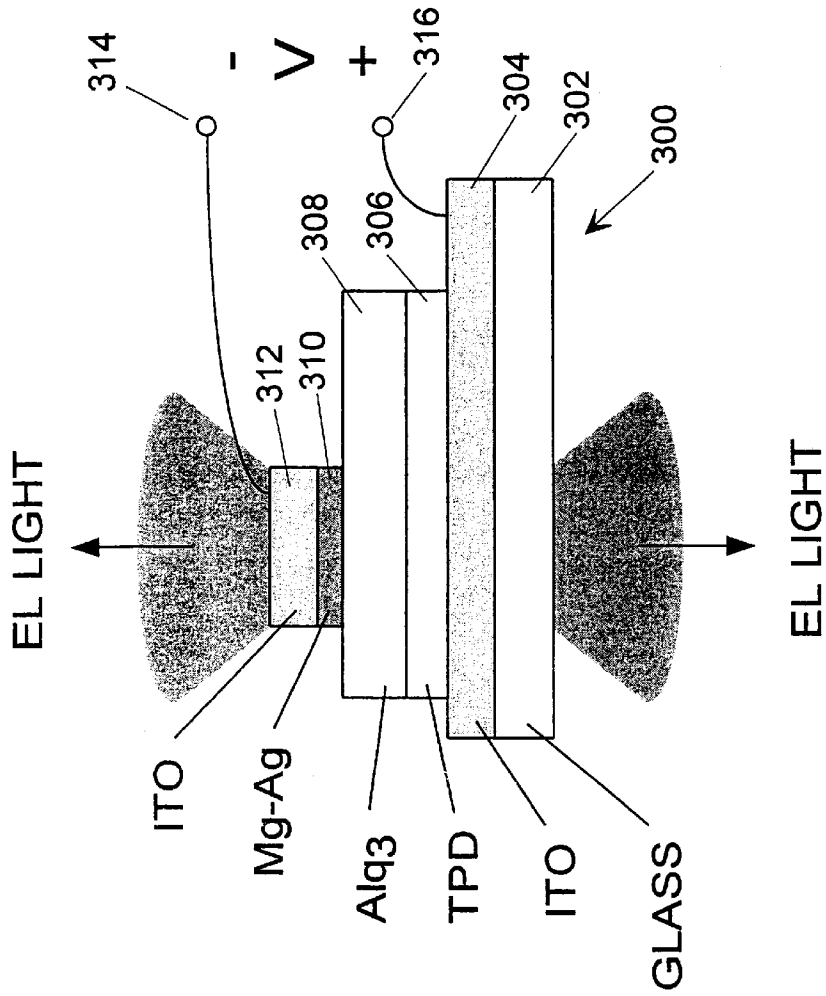

FIG. 17

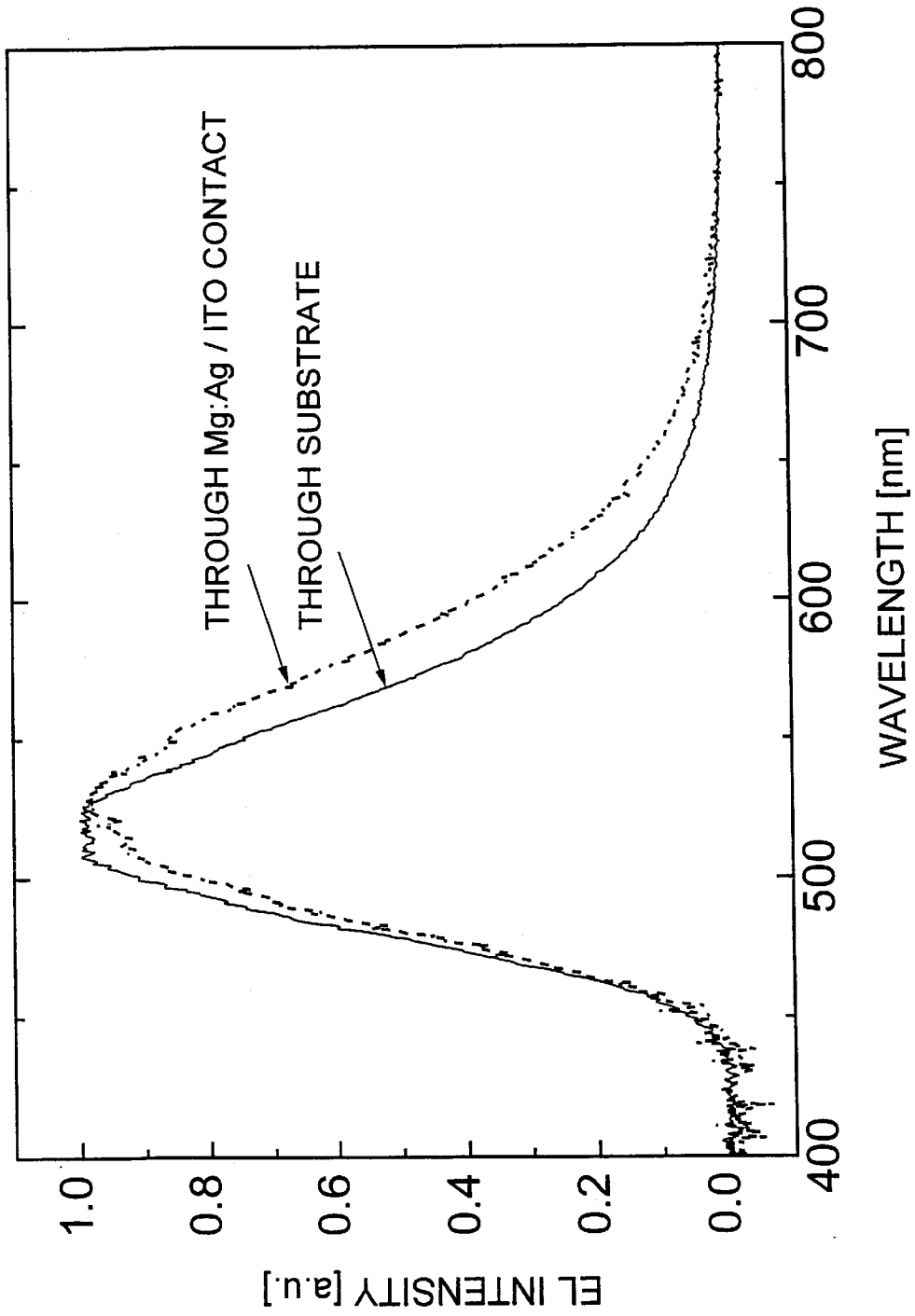

FIG. 18

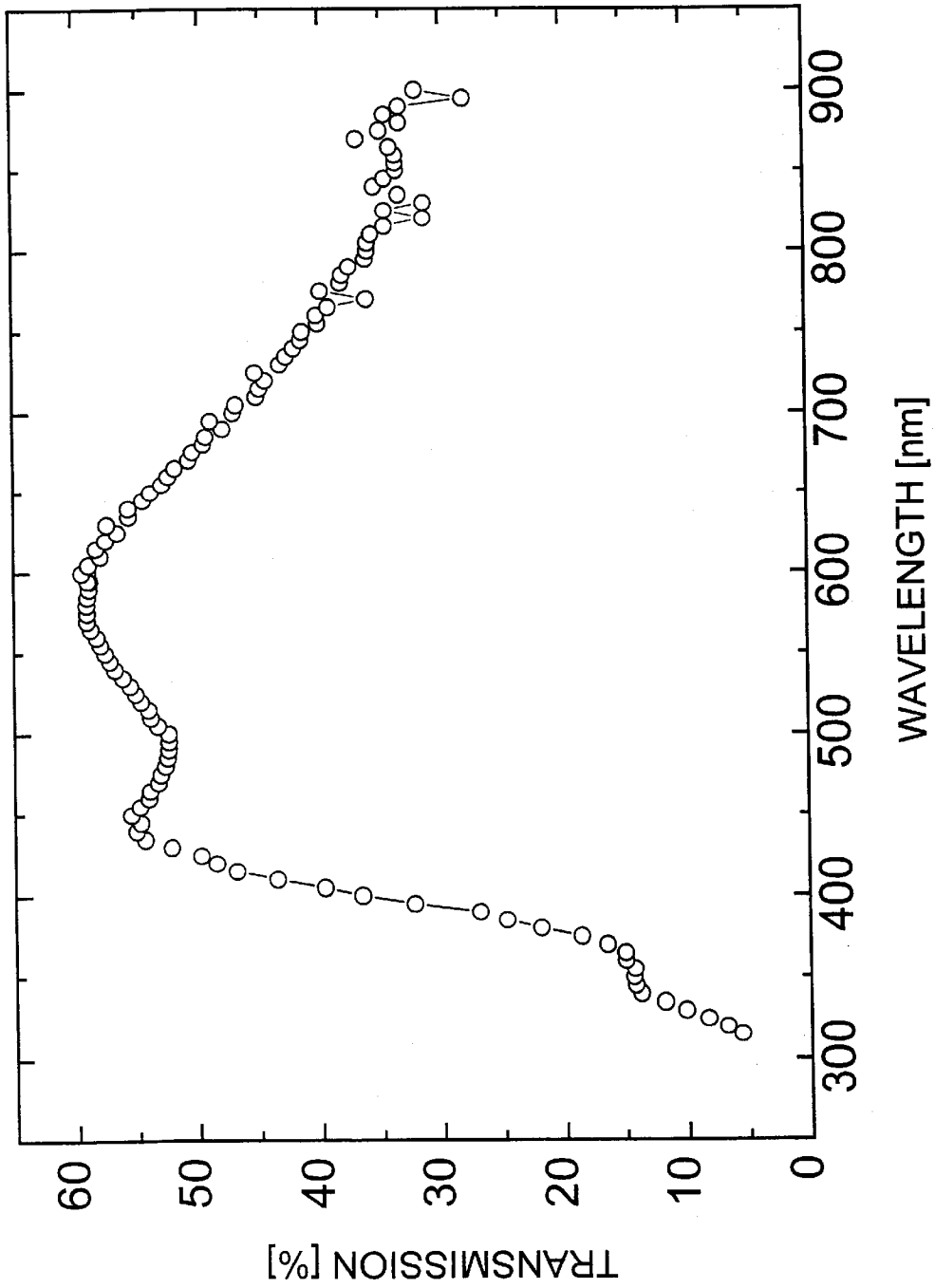

FIG. 19

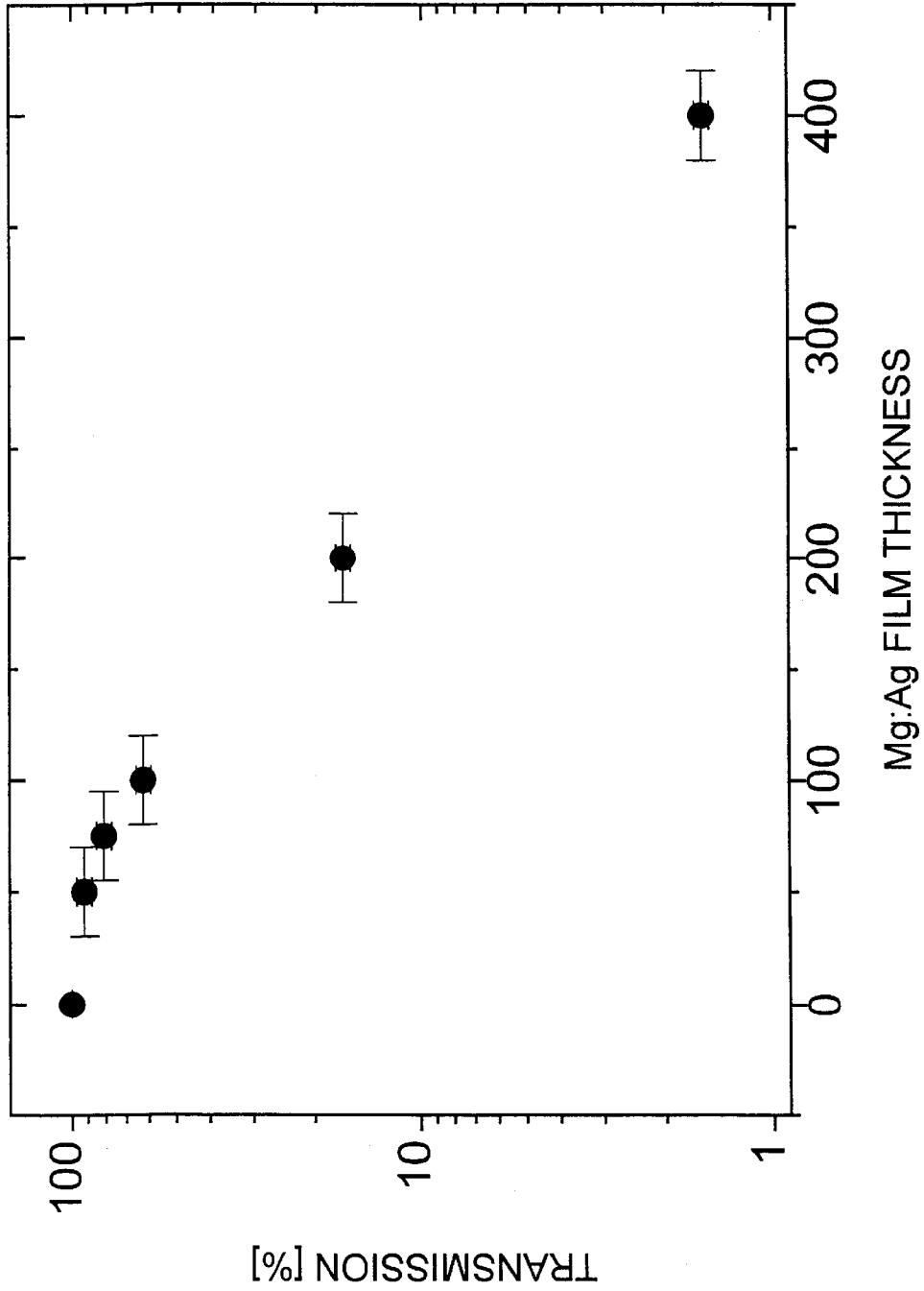

FIG. 20

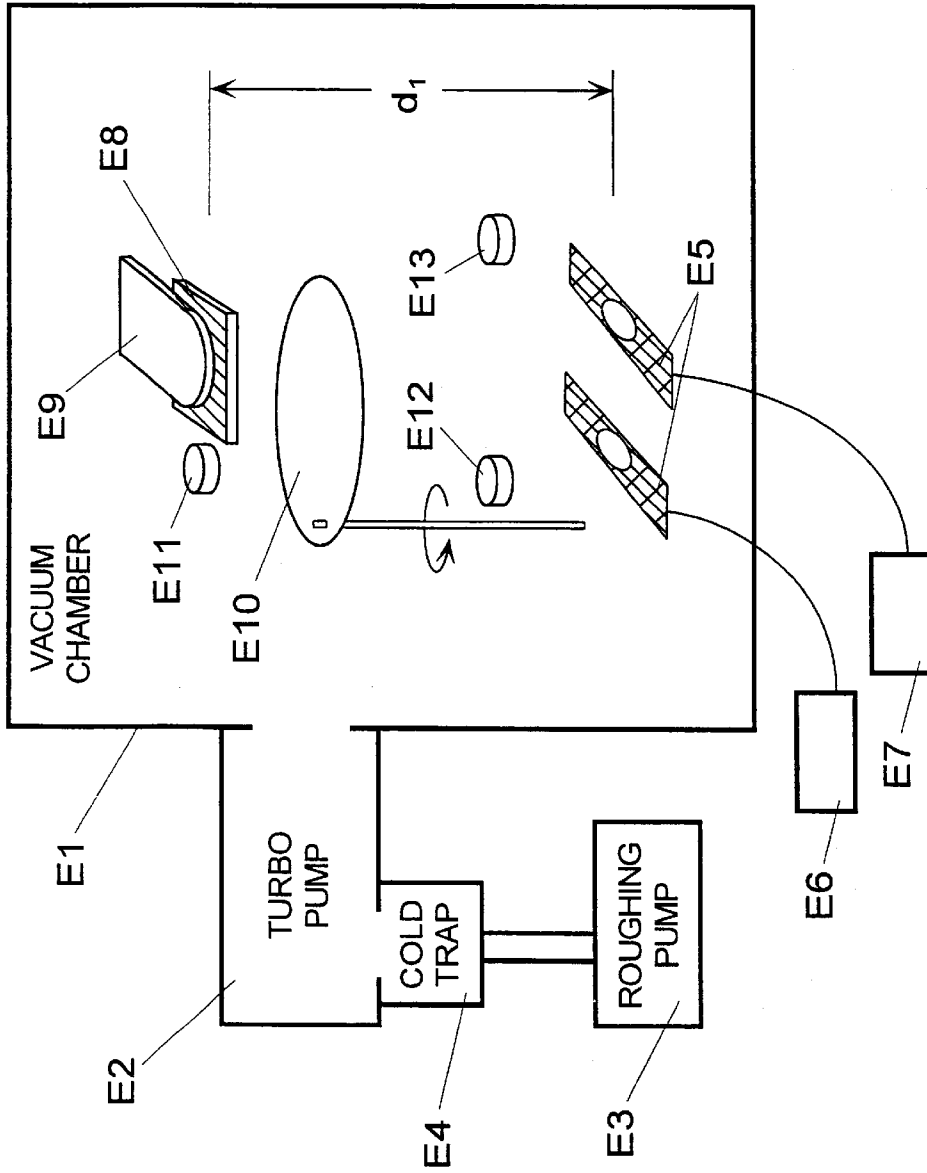

FIG. 21

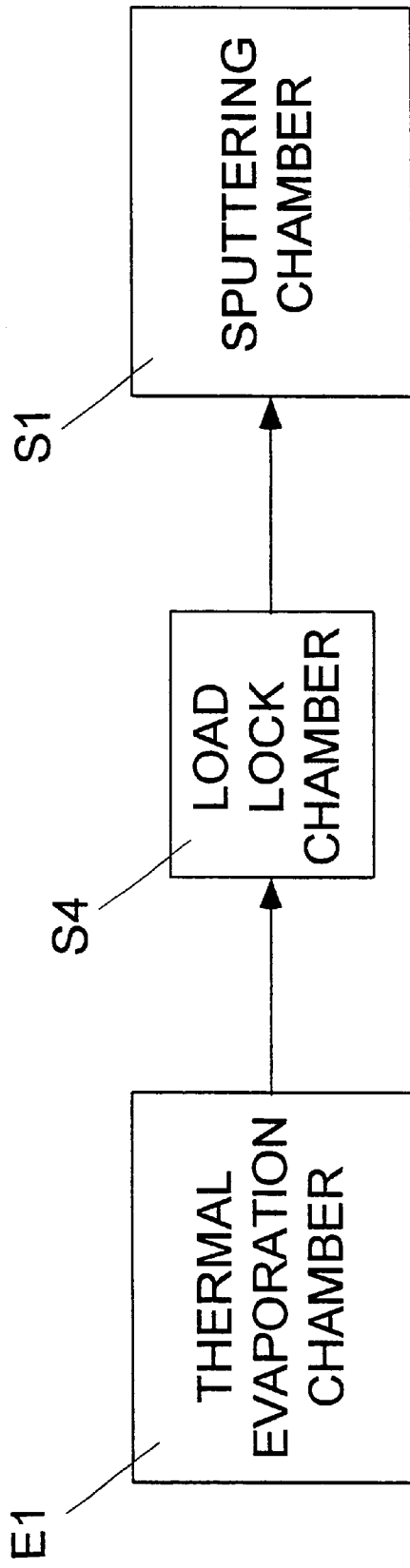

FIG. 22

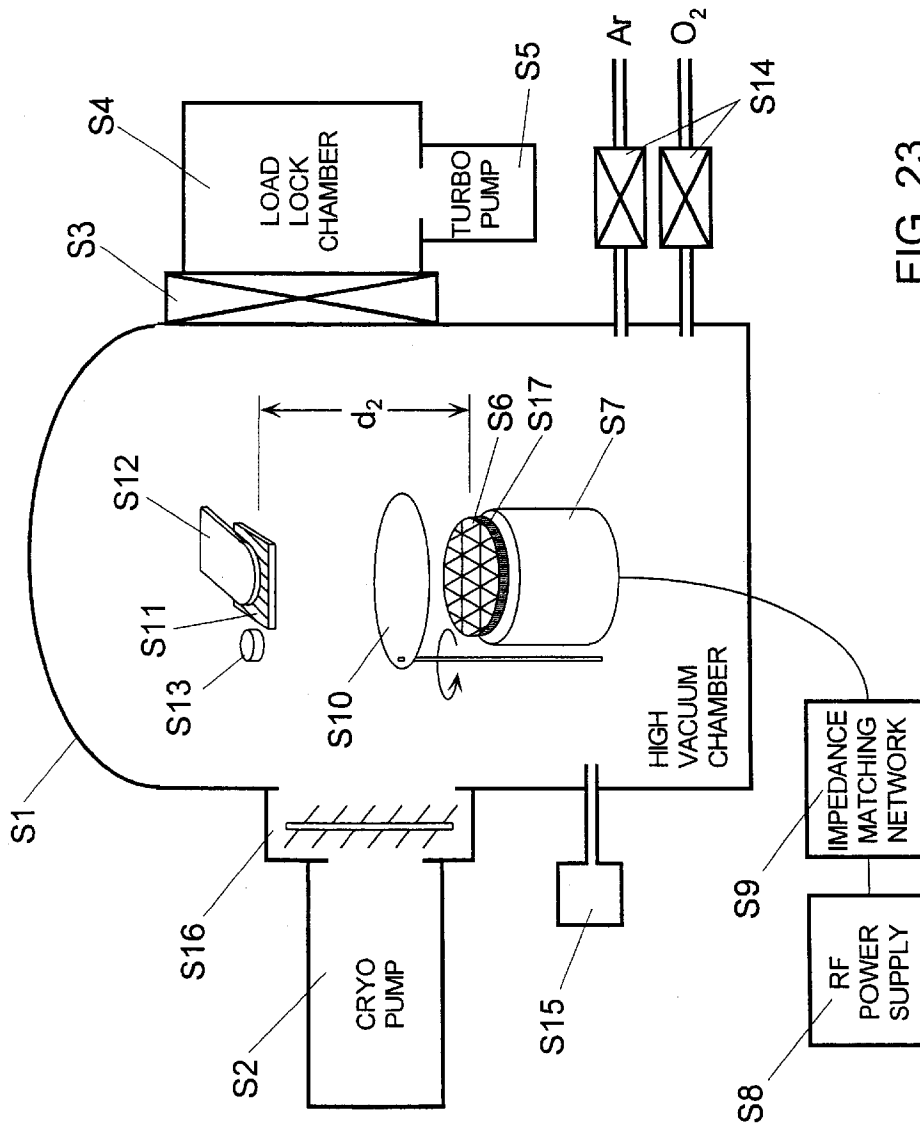

FIG. 23

METHOD OF FABRICATING TRANSPARENT CONTACTS FOR ORGANIC DEVICES

CROSS-REFERENCE TO RELATED APPLICATIONS

This application is a continuation of U.S. Ser. No. 08/872, 560, filed Jun. 10, 1997, now U.S. Pat. No. 6,264,805, which is a divisional of U.S. Ser. No. 08/613,207, filed on Mar. 6, 1996, now U.S. Pat. No. 5,703,436, which is a continuation-in-part of U.S. Ser. No. 08/354,674, filed on Dec. 13, 1994, now U.S. Pat. 5,707,745.

GOVERNMENT RIGHTS

This invention was made with Government support under Contract No. F33615-94-1-1414 awarded by DARPA. The government has certain rights in this invention.

FIELD OF THE INVENTION

This invention relates to multicolor organic light emitting devices, and more particularly to such devices for use in flat panel electronic displays, heads-up displays, and so forth.

BACKGROUND OF THE INVENTION

The electronic display is an indispensable way in modern society to deliver information and is utilized in television sets, computer terminals and in a host of other applications. No other medium offers its speed, versatility and interactivity. Known display technologies include plasma displays, light emitting diodes (LEDs), thin film electroluminescent displays, and so forth.

The primary non-emissive technology makes use of the electro optic properties of a class of organic molecules known as liquid crystals (LCs) or liquid crystal displays (LCDs). LCDs operate fairly reliably but have relatively low contrast and resolution, and require high power backlighting. Active matrix displays employ an array of transistors, each capable of activating a single LC pixel. There is no doubt that the technology concerning flat panel displays is of a significant concern and progress is continuously being made. See an article entitled "Flat Panel Displays", Scientific American, March 1993, pgs. 90-97 by S. W. Depp and W. E. Howard. In that article, it is indicated that by 1995 flat panel displays alone are expected to form a market of between 4 and 5 billion dollars. Desirable factors for any display technology is the ability to provide a high resolution full color display at good light level and at competitive pricing.

Color displays operate with the three primary colors red (R), green (G) and blue (B). There has been considerable progress in demonstrating red, green and blue light emitting devices (LEDs) using organic thin film materials. These thin film materials are deposited under high vacuum conditions. Such techniques have been developed in numerous places throughout the world and this technology is being worked on in many research facilities.

Presently, the most favored high efficiency organic emissive structure is referred to as the double heterostructure LED which is shown in FIG. 1A and designated as prior art. This structure is very similar to conventional, inorganic LED's using materials as GaAs or InP.

In the device shown in FIG. 1A, a support layer of glass 10 is coated by a thin layer of Indium Tin Oxide (ITO) 11, where layers 10 and 11 form the substrate. Next, a thin (100-500 Å) organic, predominantly hole transporting layer (HTL) 12 is deposited on the ITO layer 11. Deposited on the

surface of HTL layer 12 is a thin (typically, 50 Å-100 Å) emission layer (EL) 13. If the layers are too thin there may be lack of continuity in the film, and thicker films tend to have a high internal resistance requiring higher power operation. Emissive layer (EL) 13 provides the recombination site for electrons injected from a 100-500 Å thick electron transporting layer 14 (ETL) with holes from the HTL layer 12. The ETL material is characterized by its considerably higher electron than hole mobility. Examples of prior art ETL, EL and HTL materials are disclosed in U.S. Pat. No. 5,294,870 entitled "Organic Electroluminescent MultiColor Image Display Device", issued on Mar. 15, 1994 to Tang et al.

Often, the EL layer 13 is doped with a highly fluorescent dye to tune color and increase the electroluminescent efficiency of the LED. The device as shown in FIG. 1A is completed by depositing metal contacts 15, 16 and top electrode 17. Contacts 15 and 16 are typically fabricated from indium or Ti/Pt/Au. Electrode 17 is often a dual layer structure consisting of an alloy such as Mg/Ag 17' directly contacting the organic ETL layer 14, and a thick, high work function metal layer 17" such as gold (Au) or silver (Ag) on the Mg/Ag. The thick metal 17" is opaque. When proper bias voltage is applied between top electrode 17 and contacts 15 and 16, light emission occurs through the glass substrate 10. An LED device of FIG. 1A typically has luminescent external quantum efficiencies of from 0.05 percent to 4 percent depending on the color of emission and its structure.

Another known organic emissive structure referred to as a single heterostructure is shown in FIG. 1B and designated as prior art. The difference in this structure relative to that of FIG. 1A, is that the EL layer 13 serves also as an ETL layer, eliminating the ETL layer 14 of FIG. 1A. However, the device of FIG. 1B, for efficient operation, must incorporate an EL layer 13 having good electron transport capability, otherwise a separate ETL layer 14 must be included as shown for the device of FIG. 1A.

Presently, the highest efficiencies have been observed in green LED's. Furthermore, drive voltages of 3 to 10 volts have been achieved. These early and very promising demonstrations have used amorphous or highly polycrystalline organic layers. These structures undoubtedly limit the charge carrier mobility across the film which, in turn, limits current and increases drive voltage. Migration and growth of crystallites arising from the polycrystalline state is a pronounced failure mode of such devices. Electrode contact degradation is also a pronounced failure mechanism.

Yet another known LED device is shown in FIG. 1C, illustrating a typical cross sectional view of a single layer (polymer) LED. As shown, the device includes a glass support layer 1, coated by a thin ITO layer 3, for forming the base substrate. A thin organic layer 5 of spin-coated polymer, for example, is formed over ITO layer 3, and provides all of the functions of the HTL, ETL, and EL layers of the previously described devices. A metal electrode layer 6 is formed over organic layer 5. The metal is typically Mg, Ca, or other conventionally used metals.

An example of a multicolor electroluminescent image display device employing organic compounds for light emitting pixels is disclosed in Tang et al., U.S. Pat. No. 5,294, 870. This patent discloses a plurality of light emitting pixels which contain an organic medium for emitting blue light in blue-emitting subpixel regions. Fluorescent media are laterally spaced from the blue-emitting subpixel region. The fluorescent media absorb light emitted by the organic medium and emit red and green light in different subpixel

regions. The use of materials doped with fluorescent dyes to emit green or red on absorption of blue light from the blue subpixel region is less efficient than direct formation via green or red LED's. The reason is that the efficiency will be the product of (quantum efficiency for EL)*(quantum efficiency for fluorescence)*(1-transmittance). Thus a drawback of this display is that different laterally spaced subpixel regions are required for each color emitted.

SUMMARY OF THE INVENTION

It is an object of the present invention to provide a multicolor organic light emitting device employing several types of organic electroluminescent media, each for emitting a distinct color.

It is a further object of this invention to provide such a device in a high definition multicolor display in which the organic media are arranged in a stacked configuration such that any color can be emitted from a common region of the display.

It is another object of the present invention to provide a three color organic light emitting device which is extremely reliable, substantially transparent when de-energized, and relatively inexpensive to produce.

It is a further object to provide such a device which is implemented by the growth of organic materials similar to those materials used in electroluminescent diodes, to obtain an organic LED which is highly reliable, compact, efficient and requires low drive voltages for utilization in RGB displays.

In one embodiment of the invention, a multicolor light emitting device (LED) structure comprises at least a first and a second organic LED stacked one upon the other, and preferably three, to form a layered structure, with each LED separated one from the other by a transparent conductive layer to enable each device to receive a separate bias potential to emit light through the stack.

BRIEF DESCRIPTION OF THE DRAWINGS

FIG. 1A is a cross sectional view of a typical organic double heterostructure light emitting device (LED) according to the prior art.

FIG. 1B is a cross sectional view of a typical organic single heterostructure light emitting device (LED) according to the prior art.

FIG. 1C is a cross sectional view of a known single layer polymer LED structure according to the prior art.

FIGS. 2A, 2B, and 2C are cross sectional views of an integrated three color pixel utilizing crystalline organic light emitting devices (LED's), respectively, according to embodiments of this invention, respectively.

FIGS. 3-11 show a variety of organic compounds which may be used to comprise the active emission layers for generating the various colors.

FIGS. 12(A-E) illustrate a shadow masking process for the fabrication of the multicolor LED according to the invention.

FIGS. 13 (A-F) illustrate a dry etching process for the fabrication of the multicolor LED according to the invention.

FIG. 14A shows a multicolor LED of one embodiment of this invention configured for facilitating packaging thereof.

FIG. 14B shows a cross sectional view of a hermetic package for another embodiment of the invention.

FIG. 14C is cross sectional view taken along 14C-14C of FIG. 14B.

FIG. 15 is a block diagram showing an RGB display utilizing LED devices according to this invention together with display drive circuitry.

FIG. 16 shows an LED device of another embodiment of the invention extending the number of stacked LED's to N, where N is an integer number 1, 2, 3 . . . N.

FIG. 17 shows a substantially transparent organic light emitting device (TOLED) for another embodiment of the invention.

FIG. 18 shows the spectral output of a TOLED emitting from a 100 Å thick Mg-Ag contact (dotted line) and the associated substrate (solid line) as a plot of EL Intensity (a.u.) versus Wavelength (nm), for the embodiment of the invention of FIG. 17.

FIG. 19 is a plot of Transmission (%) versus Wavelength (nm) for showing an example of the transmission spectrum of the TOLED device of FIG. 17 with a 100 Å thick Mg-Ag electrode as a function of wavelength.

FIG. 20 shows a plot of Transmission (%) vs. Mg-Ag contact thickness at a wavelength of 530 nm, for an engineering prototype of the TOLED top contact of FIG. 17.

FIG. 21 shows a system for depositing a Mg:Ag film onto an organic layer on a substrate for one embodiment of the invention for partially forming a transparent contact on an organic layer.

FIG. 22 shows a block diagram generally showing the three successive operations that must be carried out for forming the transparent contact on an organic layer for one embodiment of the invention.

FIG. 23 shows a sputtering system for depositing an indium-tin oxide (ITO) film on top of a Mg:Ag metal alloy film previously deposited on an organic layer for one embodiment of the invention.

DETAILED DESCRIPTION OF THE INVENTION

FIG. 1A has been described and is a prior art double heterostructure organic light emitting device. The basic construction of the device of FIG. 1A is used in this invention as will be described.

Referring to FIG. 2A, there is shown a schematic cross section of a highly compact, integrated RGB pixel structure which is implemented by grown or vacuum deposited organic layers, in one embodiment of the invention. Based on the ability to grow organic materials on a large variety of materials (including metals and ITO), one can construct a stack of LED double heterostructures (DH) designated as 20, 21 and 22, in one embodiment of the invention. For illustrative purposes, LED 20 is considered in a bottom portion of the stack, LED 21 in a middle portion of the stack, and LED 22 in a top portion of the stack, in the example of FIG. 2A. Also, the stack is shown to be vertically oriented in FIG. 2A, but the LED can be otherwise oriented. In other embodiments, a stack of single heterostructure (SH) LED's (see FIG. 1B), or a stack of polymer-based LED devices (see FIG. 1C), are viable alternatives to the DH LED's, with the SH devices being equally viable as DH devices for light emitters. Also, SH and DH devices comprising a combination of vacuum deposited and polymeric light-emitting materials are considered to be within the spirit and scope of this invention.

Each device structure as device 20, consists of an HTL layer 20H vacuum-deposited or grown on or otherwise deposited onto the surface of an ITO layer 35. A top ETL layer 20T sandwiches an EL layer 20E between the former

and HTL layer **20H**, for example, shown in the device construction of FIG. **2A**. The ETL layer **20T** and other ETL layers to be described are composed of organic materials such as M(8-hydroxyquinolate)_n (M=metal ion; n=2-4). Examples of other suitable organic ETL materials can be found in U.S. Pat. No. 5,294,870 to Tang et al. Formed on top of ETL layer **20T** is a thin, semi-transparent low work function (preferably, <4 eV) metal layer **26M** having a thickness typically ranging from 50 Å to 400 Å. Suitable candidates include Mg, Mg/Ag, and As. Deposited on the top of metal layer **26M** is another transparent, thin conductive ITO layer **26I**. (For convenience herein, the double layer structure of metallic layer **26M** and ITO layer **26I** is referred to as ITO/metal layers **26**.) Each of the double heterostructure devices as **20**, **21** and **22** have a bottom HTL layer formed on a transparent conductive layer of ITO **26I** or **35**. Next an EL layer is deposited and then another layer of ETL. Each of the HTL, ETL, ITO, metal and organic EL layers are transparent because of their composition and minimal thickness. Each HTL layer may be 50 Å to greater than 1000 Å thick; each EL layer may be 50 to greater than 200 Å thick; each ETL layer may be 50 Å to greater than 1000 Å thick; each metal layer **26M** may be 50 Å to greater than 100 Å thick; and each ITO layer **26I** and **35** may be 1000 Å to greater than 4000 Å thick. For optimum performance, each of the layers should preferably be kept towards the lower ends of the above ranges, but these ranges are not meant to be limiting. Thus, each LED **20**, **21** and **22** (excluding ITO/metal layers) are preferably close to 200 Å thick.

If SH LED devices are used for providing LED's **20**, **21**, **22**, rather than DH LED devices, the ETL and EL layers are provided by a single layer, such as layer **13**, as previously described for the SH of FIG. **1B**. This layer **13** is typically Al-quinolate. This is shown in FIG. **2B**, where the EL layers **20E**, **21E**, and **22E**, respectively, provide both the EL and ETL layer functions. However, an advantage of the DH LED stack of FIG. **2A**, relative to a SH LED stack of FIG. **2B**, is that the DH LED stack permits thinner overall construction with high efficiency.

In FIGS. **2A** and **2B**, even though the centers of each of the LED's are offset from one another, the total beam of light from each device is substantially coincident between LED's **20**, **21** and **22**. While the beams of light are coincident in the concentric configuration, the emitting or non-emitting device closer to the glass substrate will be transparent to the emitting device or devices further away from the glass substrate. However, the diodes **20**, **21** and **22** need not be offset from one another and may alternatively be stacked concentrically upon each other, whereupon the beam of light from each device is wholly coincident with the others. A concentric configuration is shown in FIG. **12E** which will be described below in regard to device fabrication processes. Note that there is no difference in function between the offset and concentric configurations. Each device emits light through glass substrate **37** in a substantially omnidirectional pattern. The voltages across the three LED's in the stack **29** are controlled to provide a desired resultant emission color and brightness for the particular pixel at any instant of time. Thus, each LED as **22**, **21** and **20** can be energized simultaneously with beams as R, G and B, respectively, for example, directed through and visible via the transparent layers, as shown schematically in FIGS. **2A** and **2B**. Each DH structure **20**, **21** and **22** is capable upon application of a suitable bias voltage of emitting a different color light. The double heterostructure LED **20** emits blue light. The double heterostructure LED **21** emits green light while the double heterostructure (DH) LED **22** emits red light. Different

combinations or individual ones of LED's **20**, **21** and **22** can be activated to selectively obtain a desired color of light for the respective pixel partly dependent upon the magnitude of current in each of the LED's **20**, **21** and **22**.

In the example of FIGS. **2A** and **2B**, LED's **20**, **21** and **22** are forward biased by batteries **32**, **31** and **30**, respectively. Current flows from the positive terminal of each battery **32**, **31** and **30**, into the anode terminals **40**, **41**, **42**, respectively, of its associated LED **20**, **21** and **22**, respectively, through the layers of each respective device, and from terminals **41**, **42** and **43**, serving as cathode terminals to negative terminals of each battery **32**, **31**, and **30**, respectively. As a result, light is emitted from each of the LED's **20**, **21** and **22**. The LED devices **20**, **21** and **22** are made selectively energizable by including means (not shown) for selectively switching batteries **32**, **31** and **30**, respectively, into and out of connection to their respective LED.

In the embodiments of the invention, relative to FIGS. **2A** and **2B**, the top ITO contact **26I** for LED **22** is transparent, making the three color device shown useful for heads-up display applications. However, in another embodiment of the invention, the top contact **26I** is formed from a thick metal, such as either Mg/Ag, In, Ag, or Au, for reflecting light emitted upward back through substrate **13**, for substantially increasing the efficiency of the device. Also, overall device efficiency can be increased by forming a multilayer dielectric thin film coating between glass substrate **37** and the ITO layer **35**, to provide an anti-reflecting surface. Three sets of anti-reflecting layers are required, one to form an anti-reflection coating at each wavelength emitted from the various layers.

In another embodiment, the device of FIG. **2A** is constructed in an opposite or inverted manner, for providing light emission out of the top of stack rather than the bottom as the former. An example of an inverted structure, with reference to FIG. **2C**, is to replace ITO layer **35** with a thick, reflective metal layer **38**. Blue LED **20** is then provided by interchanging HTL layer **20H** and ETL layer **20T**, with EL layer **20E** remaining sandwiched between the latter two layers. Furthermore, the metal contact layer **26M** is now deposited on top of ITO layer **26I**. The green LED **21** and red LED **22** portions of the stack are each constructed with inverted layers (the HTL and ETL layers of each are interchanged, followed by inverting the metal and ITO layers) as described for the inverted blue LED **20**. Note that in the inverted structure, the blue device **20** must be on top and the red device **22** on the bottom. Also, the polarities of batteries **30**, **31**, and **32** are reversed. As a result, the current flow through devices **20**, **21** and **22**, respectively, is in the same direction relative to the embodiment of FIG. **2A**, when forward biased for emitting light.

The device in the cross sectional view has a step-like or staircase profile, in this example. The transparent contact areas (ITO) **26I** permit separate biasing of each pixel element in the stack and furthermore the material can be used as an etch stop during the processing steps. The separate biasing of each DH LED structure **20**, **21** and **22** allows for wavelength tuning of the pixel output to any of various desired colors of the visible spectrum as defined in the CIE (Commission Internationale de l'Eclairage/International Commission of Illumination) chromaticity standard. The blue emitting LED **20** is placed at the bottom of the stack and it is the largest of the three devices. Blue is on the bottom because it is transparent to red and green light. Finally, the materials "partitioning" using the transparent ITO/metal layers **26** facilitates manufacture of this device as will be described. It is the very unique aspects of the vacuum

growth and fabrication processes associated with organic compounds which makes the pixel LED devices shown in FIGS. 2A, 2B, and 2C possible. The vertical layering shown in FIGS. 2A, 2B, and 2C allows for the fabrication of three color pixels with the smallest possible area, hence, making these ideal for high definition displays.

As seen in FIGS. 2A, 2B, and 2C, each device DH structure 20, 21 and 22 can emit light designated by arrows B, G and R, respectively, either simultaneously or separately. Note that the emitted light is from substantially the entire transverse portion of each LED 20, 21 and 22, whereby the R, G, and B arrows are not representative of the width of the actual emitted light, respectively. In this way, the addition or subtraction of colors as R, G and B is integrated by the eye causing different colors and hues to be perceived. This is well known in the field of color vision and display colorimetry. In the offset configuration shown, the red, green and blue beams of light are substantially coincident. Any one of a variety of colors can be produced from the stack, and it will appear as one color originating from a single pixel.

The organic materials used in the DH structures are grown one on top of the other or are vertically stacked with the longest wavelength device 22 indicative of red light on the top and the shortest wavelength element 20 indicative of blue light on the bottom. In this manner, one minimizes light absorption in the pixel or in the devices. Each of the DH LED devices are separated by ITO/metal layers 26 (specifically, semitransparent metal layers 26M, and indium tin oxide layers 26I). The ITO layers 26I can further be treated by metal deposition to provide distinct contact areas on the exposed ITO surfaces, such as contacts 40, 41, 42 and 43. These contacts 40, 41, 42 and 43 are fabricated from indium, platinum, gold, silver or alloys such as Ti/Pt/Au, Cr/Au, or Mg/Ag, for example. Techniques for deposition of contacts using conventional metal deposition or vapor deposition are well known. The contacts, such as 40, 41, 42 and 43, enable separate biasing of each LED in the stack. The significant chemical differences between the organic LED materials and the transparent electrodes 26I permits the electrodes to act as etch stop layers. This allows for the selective etching and exposure of each pixel element during device processing.

Each LED 20, 21, 22 has its own source of bias potential, in this example shown schematically as batteries 32, 31, and 30, respectively, which enables each LED to emit light. It is understood that suitable signals can be employed in lieu of the batteries 30, 31, 32, respectively. As is known, the LED requires a minimum threshold voltage to emit light (each DH LED) and hence this activating voltage is shown schematically by the battery symbol.

The EL layers 20E, 21E, 22E may be fabricated from organic compounds selected according to their ability to produce all primary colors and intermediates thereof. The organic compounds are generally selected from trivalent metal quinolate complexes, trivalent metal bridged quinolate complexes, Schiff base divalent metal complexes, tin (iv) metal complexes, metal acetylacetonate complexes, metal bidentate ligand complexes, bisphosphonates, divalent metal maleonitriledithiolate complexes, molecular charge transfer complexes, aromatic and heterocyclic polymers and rare earth mixed chelates, as described hereinafter.

The trivalent metal quinolate complexes are represented by the structural formula shown in FIG. 3, wherein M is a trivalent metal ion selected from Groups 3–13 of the Periodic Table and the Lanthanides. Al^{+3} , Ga^{+3} and In^{+3} are the preferred trivalent metal ions.

R of FIG. 3 includes hydrogen, substituted and unsubstituted alkyl, aryl and heterocyclic groups. The alkyl group may be straight or branched chain and preferably has from 1 to 8 carbon atoms. Examples of suitable alkyl groups are methyl and ethyl. The preferred aryl group is phenyl and examples of the heterocyclic group for R include pyridyl, imidazole, furan and thiophene.

The alkyl, aryl and heterocyclic groups of R may be substituted with at least one substituent selected from aryl, halogen, cyano and alkoxy, preferably having from 1 to 8 carbon atoms. The preferred halogen is chloro.

The group L of FIG. 3 represents a ligand including picolylmethylketone, substituted and unsubstituted salicylaldehyde substituted with barbituric acid), a group of the formula $R(O)CO-$ wherein R is as defined above, halogen, a group of the formula $RO-$ wherein R is as defined above, and quinolates (e.g. 8-hydroxyquinoline) and derivatives thereof (e.g. barbituric acid substituted quinolates). Preferred complexes covered by the formula shown in FIG. 3 are those where M is Ga^{+3} and L is chloro. Such compounds generate a blue emission. When M is Ga^{+3} and L is methyl carboxylate, complexes emitting in the blue to blue/green region are produced. A yellow or red emission is expected by using either a barbituric acid substituted salicylaldehyde or a barbituric acid substituted 8-hydroxyquinoline for the L group. Green emissions may be produced by using a quinolate for the L group.

The trivalent metal bridged quinolate complexes which may be employed in the present invention are shown in FIGS. 4A and 4B. These complexes generate green emissions and exhibit superior environmental stability compared to trisquinolates (complexes of FIG. 3 where L is a quinolate) used in prior art devices. The trivalent metal ion M used in these complexes is as defined above with Al^{+3} , Ga^{+3} , or In^{+3} being preferred. The group Z shown in FIG. 4A has the formula SiR wherein R is as defined above. Z may also be a group of the formula $P=O$ which forms a phosphate.

The Schiff base divalent metal complexes include those shown in FIGS. 5A and 5B wherein M^1 is a divalent metal chosen from Groups 2–12 of the Periodic Table, preferably Zn (See, Y. Hanada, et al., "Blue Electroluminescence in Thin Films of Axomethin-Zinc Complexes", *Japanese Journal of Applied Physics* Vol. 32, pp. L511–L513 (1993)). The group R^1 is selected from the structural formulas shown in FIGS. 5A and 5B. The R^1 group is preferably coordinated to the metal of the complex through the amine or nitrogen of the pyridyl group. X is selected from hydrogen, alkyl, alkoxy, each having from 1 to 8 carbon atoms, aryl, a heterocyclic group, phosphino, halide and amine. The preferred aryl group is phenyl and the preferred heterocyclic group is selected from pyridyl, imidazole, furan and thiophene. The X groups affect the solubility of the Schiff base divalent metal complexes in organic solvents. The particular Schiff base divalent metal complex shown in FIG. 5B emits at a wavelength of 520 nm.

The tin (iv) metal complexes employed in the present invention in the EL layers generate green emissions. Included among these complexes are those having the formula $SnL^1_2L^2_2$ where L^1 is selected from salicylaldehydes, salicylic acid or quinolates (e.g. 8-hydroxyquinoline). L^2 includes all groups as previously defined for R except hydrogen. For example, tin (iv) metal complexes where L^1 is a quinolate and L^2 is phenyl have an emission wavelength (λ_{em}) of 504 nm, the wavelength resulting from measurements of photoluminescence in the solid state.

The tin (iv) metal complexes also include those having the structural formula of FIG. 6 wherein Y is sulfur or NR² where R² is selected from hydrogen and substituted or unsubstituted, alkyl and aryl. The alkyl group may be straight or branched chain and preferably has from 1 to 8 carbon atoms. The preferred aryl group is phenyl. The substituents for the alkyl and aryl groups include alkyl and alkoxy having from 1 to 8 carbon atoms, cyano and halogen. L³ may be selected from alkyl, aryl, halide, quinolates (e.g. 8-hydroxyquinoline), salicylaldehydes, salicylic acid, and maleonitriledithiolate ("mnt"). When A is S and Y is CN and L³ is "mnt" an emission between red and orange is expected.

The M (acetylacetonate)₃ complexes shown in FIG. 7 generate a blue emission. The metal ion M is selected from trivalent metals of Groups 3–13 of the Periodic Table and the Lanthanides. The preferred metal ions are Al⁺³, Ga⁺³ and In⁺³. The group R in FIG. 7 is the same as defined for R in FIG. 3. For example, when R is methyl, and M is selected from Al⁺³, Ga⁺³ and In⁺³, respectively, the wavelengths resulting from the measurements of photoluminescence in the solid state is 415 nm, 445 nm and 457 nm, respectively (See J. Kido et al., "Organic Electroluminescent Devices using Lanthanide Complexes", *Journal of Alloys and Compounds*, Vol. 92, pp. 30–33 (1993).

The metal bidentate complexes employed in the present invention generally produce blue emissions.

Such complexes have the formula MDL₂⁴ wherein M is selected from trivalent metals of Groups 3–13 of the Periodic Table and the Lanthanides. The preferred metal ions are Al⁺³, Ga⁺³, In⁺³ and Sc⁺³. D is a bidentate ligand examples of which are shown in FIG. 8A. More specifically, the bidentate ligand D includes 2-picolyketones, 2-quinaldylketones and 2-(o-phenoxy)pyridine ketones where the R groups in FIG. 8A are as defined above.

The preferred groups for L⁴ include acetylacetonate; compounds of the formula OR³R wherein R³ is selected from Si, C and R is selected from the same groups as described above; 3,5-di(t-bu)phenol; 2,6-di(t-bu)phenol; 2,6-di(t-bu)cresol; and H₂Bpz₂, the latter compounds being shown in FIGS. 8B–8E, respectively.

By way of example, the wavelength (λ_{em}) resulting from measurement of photoluminescence in the solid state of aluminum(picolylmethylketone)bis[2,6-di(t-bu)phenoxide] is 420 nm. The cresol derivative of the above compound also measured 420 nm. Aluminum(picolylmethylketone)bis(OSiPh₃) and scandium(4-methoxy-picolylmethylketone) bis(acetylacetonate) each measured 433 nm, while aluminum[2-(O-phenoxy)pyridine]bis[2,6-di(t-bu)phenoxide] measured 450 nm.

Bisphosphonate compounds are another class of compounds which may be used in accordance with the present invention for the EL layers. The bisphosphonates are represented by the general formula:

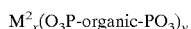

M² is a metal ion. It is a tetravalent metal ion (e.g. Zr⁺⁴, Ti⁺⁴ and Hf⁺⁴ when x and y both equal 1. When x is 3 and y is 2, the metal ion M² is in the divalent state and includes, for example, Zn⁺², Cu⁺² and Cd⁺². The term "organic" as used in the above formula means any aromatic or heterocyclic fluorescent compound that can be bifunctionalized with phosphonate groups.

The preferred bisphosphonate compounds include phenylene vinylene bisphosphonates as for example those shown in FIGS. 9A and 9B. Specifically, FIG. 9A shows β -styrenyl stilbene bisphosphonates and FIG. 9B shows

4,4'-biphenyl di(vinylphosphonates) where R is as described previously and R⁴ is selected from substituted and unsubstituted alkyl groups, preferably having 1–8 carbon atoms, and aryl. The preferred alkyl groups are methyl and ethyl. The preferred aryl group is phenyl. The preferred substituents for the alkyl and aryl groups include at least one substituent selected from aryl, halogen, cyano, alkoxy, preferably having from 1 to 8 carbon atoms.

The divalent metal maleonitriledithiolate ("mnt") complexes have the structural formula shown in FIG. 10. The divalent metal ion M³ includes all metal ions having a +2 charge, preferably transition metal ions such as Pt⁺², Zn⁺² and Pd⁺². Y¹ is selected from cyano and substituted or unsubstituted phenyl. The preferred substituents for phenyl are selected from alkyl, cyano, chloro and 1,2,2-tricyanovinyl.

L⁵ represents a group having no charge. Preferred groups for L⁵ include P(OR)₃ and P(R)₃ where R is as described above or L⁵ may be a chelating ligand such as, for example, 2,2'-dipyridyl; phenanthroline; 1,5-cyclooctadiene; or bis(diphenylphosphino)methane.

Illustrative examples of the emission wavelengths of various combinations of these compounds are shown in Table 1, as derived from C. E. Johnson et al., "Luminescent Iridium(I), Rhodium(I), and Platinum(II) Dithiolate Complexes", *Journal of the American Chemical Society*, Vol. 105, pg. 1795 (1983).

TABLE 1

Complex	Wavelength*
[Platinum(1, 5-cyclooctadiene)(mnt)]	560 nm
[Platinum(P(OEt) ₃) ₂ (mnt)]	566 nm
[Platinum(P(OPh) ₃) ₂ (mnt)]	605 nm
[Platinum(bis(diphenylphosphino)methane)(mnt)]	610 nm
[Platinum(PPh ₃) ₂ (mnt)]	652 nm

*wavelength resulting from measurement of photoluminescence in the solid state.

Molecular charge transfer complexes employed in the present invention for the EL layers are those including an electron acceptor structure complexed with an electron donor structure. FIGS. 11A–11E show a variety of suitable electron acceptors which may form a charge transfer complex with one of the electron donor structures shown in FIGS. 11F–11J. The group R as shown in FIGS. 11A and 11H is the same as described above.

Films of these charge transfer materials are prepared by either evaporating donor and acceptor molecules from separate cells onto the substrate, or by evaporating the pre-made charge transfer complex directly. The emission wavelengths may range from red to blue, depending upon which acceptor is coupled with which donor.

Polymers of aromatic and heterocyclic compounds which are fluorescent in the solid state may be employed in the present invention for the EL Layers. Such polymers may be used to generate a variety of different colored emissions. Table II provides examples of suitable polymers and the color of their associated emissions.

TABLE II

POLYMER	EMISSION COLOR
poly(para-phenylenevinylene)	blue to green
poly(dialkoxyphenylenevinylene)	red/orange
poly(thiophene)	red
poly(phenylene)	blue

TABLE II-continued

POLYMER	EMISSION COLOR
poly(phenylacetylene)	yellow to red
poly(N-vinylcarbazole)	blue

The rare earth mixed chelates for use in the present invention include any lanthanide elements (e.g. La, Pr, Nd, Sm, Eu, and Tb) bonded to a bidentate aromatic or heterocyclic ligand. The bidentate ligand serves to transport carriers (e.g. electrons) but does not absorb the emission energy. Thus, the bidentate ligands serve to transfer energy to the metal. Examples of the ligand in the rare earth mixed chelates include salicylaldehydes and derivatives thereof, salicylic acid, quinolates, Schiff base ligands, acetylacetonates, phenanthroline, bipyridine, guinoline and pyridine.

The hole transporting layers **20H**, **21H** and **22H** may be comprised of a porphorinic compound. In addition, the hole transporting layers **20H**, **21H** and **22H** may have at least one hole transporting aromatic tertiary amine which is a compound containing at least one trivalent nitrogen atom that is bonded only to carbon atoms, at least one of which is a member of an aromatic ring. For example, the aromatic tertiary amine can be an arylamine, such as a monoarylamine, diarylamine, triarylamine, or a polymeric arylamine. Other suitable aromatic tertiary amines, as well as all porphyrinic compounds, are disclosed in Tang et al., U.S. Pat. No. 5,294,870, the teachings of which are incorporated herein in their entirety by reference, provided any of such teachings are not inconsistent with any teaching herein.

The fabrication of a stacked organic LED tricolor pixel according to the present invention may be accomplished by either of two processes: a shadow masking process or a dry etching process. Both processes to be described assume, for illustrative purposes, a double heterostructure LED construction, i.e., utilizing only one organic compound layer for each active emission layer, with light emerging from the bottom glass substrate surface. It should be understood that multiple heterojunction organic LEDs having multiple organic compound layers for each active emission layer, and/or inverted structures (with light emerging from the top surface of the stack) can also be fabricated by one skilled in the art making slight modifications to the processes described.

The shadow masking process steps according to the present invention are illustrated in FIGS. **12(A-E)**. A glass substrate **50** to be coated with a layer of ITO **52** is first cleaned by immersing the substrate **50** for about five minutes in boiling trichloroethylene or a similar chlorinated hydrocarbon. This is followed by rinsing in acetone for about five minutes and then in methyl alcohol for approximately five minutes. The substrate **50** is then blown dry with ultrahigh purity (UHP) nitrogen. All of the cleaning solvents used are preferably "electronic grade". After the cleaning procedure, the ITO layer **52** is formed on substrate **50** in a vacuum using conventional sputtering or electron beam methods.

A blue emitting LED **55** (see FIG. **12B**) is then fabricated on the ITO layer **52** as follows. A shadow mask **73** is placed on predetermined outer portions of the ITO layer **52**. The shadow mask **73** and other masks used during the shadow masking process should be introduced and removed between process steps without exposing the device to moisture, oxygen and other contaminants which would reduce the operational lifetime of the device. This may be accomplished by changing masks in an environment flooded with

nitrogen or an inert gas, or by placing the masks remotely onto the device surface in the vacuum environment by remote handling techniques. Through the opening of mask **73**, a 50–100 Å thick hole transporting layer (HTL) **54** and 50–200 Å thick blue emission layer (EL) **56** (shown in FIG. **12B**) are sequentially deposited without exposure to air, i.e., in a vacuum. An electron transporting layer (ETL) **58** having a thickness preferably of 50–1000 Å is then deposited on EL **56**. ETL **58** is then topped with a semitransparent metal layer **60M** which may preferably consist of a 10% Ag in 90% Mg layer, or other low work function metal or metal alloy layer, for example. Layer **60M** is very thin, preferably less than 100 Å. Layers **54**, **56**, **58** and **60M** may be deposited by any one of a number of conventional directional deposition techniques such as vapor phase deposition, ion beam deposition, electron beam deposition, sputtering and laser ablation.

An ITO contact layer **60I** of about 1000–4000 Å thick is then formed on the metal layer **60M** by means of conventional sputtering or electron beam methods. For convenience herein, the sandwich layers **60M** and **60I** will be referred to and shown as a single layer **60**, which is substantially the same as the layer **26** of FIG. **2**. The low work function metal portion **60M** of each layer **60** directly contacts the ETL layer beneath it, while the ITO layer **60I** contacts the HTL layer immediately above it. Note that the entire device fabrication process is best accomplished by maintaining the vacuum throughout without disturbing the vacuum between steps.

FIG. **12C** shows a green emitting LED **65** which is fabricated on top of layer **60** using substantially the same shadow masking and deposition techniques as those used to fabricate blue emitting LED **55**. LED **65** comprises HTL **62**, green emission layer **64** and ETL **66**. A second thin (<100 Å thick, thin enough to be semi-transparent but not so thin to lose electrical continuity) metal layer **60M** is deposited on ETL layer **66**, followed by another 1000–4000 Å thick ITO layer **60I** to form a second sandwich layer **60**.

Shown in FIG. **12D** is a red emitting LED **75** fabricated upon layer **60** (upon **60I** to be specific) using similar shadow masking and metal deposition methods. Red emitting LED **75** consists of a HTL **70**, a red emitting EL **72** and ETL **74**. A top sandwich layer **60** of layers **60I** and **60M** are then formed on LED **75**. As described above for the embodiment of FIG. **2**, similarly, the top transparent ITO layer **60I** can in an alternative embodiment be replaced by an appropriate metal electrode serving also to function as a mirror for reflecting upwardly directed light back through the substrate **50**, thereby decreasing light losses out of the top of the device. Each ETL layer **74**, **66** and **58** has a thickness of 50–200 Å; each HTL layer **54**, **62** and **70** is 100–500 Å thick; and each EL layer **56**, **64** and **72** is 50–1000 Å thick. For optimum brightness and efficiency, each of the layers including the ITO/metal layers should be kept as close as possible towards the lower end of the above ranges, but these ranges are not meant to be limiting.

The formation of electrical contacts **51** and **59** on ITO layer **52**, and electrical contacts **88**, **89**, **92**, **94** and **96** on the ITO portion **60I** of ITO/metal layers **60** is then preferably accomplished in one step. These electrical contacts may be indium, platinum, gold, silver or combinations such as Ti/Pt/Au, Cr/Au or Mg/Ag. They may be deposited by vapor deposition or other suitable metal deposition techniques after masking off the rest of the device.

The final step in the shadow masking process is to overcoat the entire device with an insulating layer **97** as shown in FIG. **12E**, with the exception of all the metal contacts **51**, **59**, **88**, **89**, **92**, **94** and **96** which are masked.

Insulating layer **97** is impervious to moisture, oxygen and other contaminants thereby preventing contamination of the LEDs. Insulating layer **97** may be SiO₂, a silicon nitride such as Si₂N₃ or other insulator deposited by electron-beam, sputtering, or pyrolytically enhanced or plasma enhanced CVD. The deposition technique used should not elevate the device temperature above 120° C. inasmuch as these high temperatures may degrade the LED characteristics. Note that the 120° C. is variable, and represents the softening point of typical organic materials used in the present invention.

The dry etching process for fabricating the LED stack according to the invention is illustrated in FIGS. **13(A-F)**. Referring to FIG. **13A**, a glass substrate **102** is first cleaned in the same manner as in the shadow-mask process described above. An ITO layer **101** is then deposited on the glass substrate **102** in a vacuum using conventional sputtering or electron beam methods. An HTL **104**, blue EL **105**, ETL **106** and sandwich layer comprising metal layer **107M** and ITO layer **107I**, all of generally the same thicknesses as in the shadow-masking process, are then deposited over the full surface of the ITO layer **101**, using either conventional vacuum deposition, or in the case of polymers spin or spray coating techniques. ITO/metal sandwich layer **107** consists of a less than 100 Å thick, low work function metal layer **107M** deposited directly on the ETL layer **106**, and a 1000–4000 Å thick ITO layer **107I** on the metal layer **107M**. on the entire top surface of ITO layer **107I**, a 1000 Å–2000 Å thick layer of silicon nitride or silicon dioxide masking material **108** is deposited using low temperature plasma CVD. A positive photoresist layer **109** such as HPR 1400 J is then spun-on the silicon nitride layer **108**. As shown in FIG. **13B** the outer portions **110** (see FIG. **13A**) of the photoresist layer **109** are exposed and removed using standard photolithographic processes. The exposed outer portions **110** correspond to the areas where the bottom ITO layer **101** is to be exposed and electrically contacted. Referring to FIG. **13C**, the outer regions **111** (defined in FIG. **13B**) of the silicon nitride layer **108** corresponding to the removed photoresist areas, are removed using a CF₄:O₂ plasma. Then, using an ion milling technique or another plasma etch, the exposed outer portions of ITO/metal layers **107I** and **107M** are removed. An O₂ plasma is then employed to sequentially remove the corresponding exposed outer portion of the ETL layer **106**, EL layer **105**, and HTL layer **104**, respectively, and also to remove the remaining photoresist layer **109** shown in FIG. **13D**. Finally, a CF₄:O₂ plasma is again applied to remove the silicon nitride mask **108**, with the resulting blue LED configuration shown in FIG. **13D**.

The same sequence of dry etching process steps is used to fabricate a green LED **115** atop the blue LED, except that SiNx **150** is overlaid as shown, followed by a photoresist mask **113** as shown in FIG. **13E** to mask the outer portion of ITO layer **101**. Then the deposition of HTL layer **114**, green EL layer **116**, and so on is performed (see FIG. **13F**). The same photolithography and etching techniques used for blue LED fabrication are then employed to complete the formation of the green LED **115**. The red LED **117** is then formed atop the green LED using substantially the same dry etching process. A passivation layer **119** similar to layer **97** of FIG. **12E** is then deposited over the LED stack with suitable patterning to expose electrical contacts, as was described for the shadow masking process. A photoresist mask is used to allow dry etching of holes in passivation layer **119**. Next, metal **152** is deposited in the holes. A final photoresist layer and excess metal is removed by a “lift-off” process.

Following the LED stack fabrication, whether performed by a shadow mask, dry-etching or other method, the stack

must be properly packaged to achieve acceptable device performance and reliability. FIGS. **14(A-C)** illustrate embodiments of the invention for facilitating packaging, and for providing a hermetic package for up to four of the multicolor LED devices of the invention, for example. The same reference numerals used in FIGS. **14 (A-B)** indicate the identical respective features as in FIG. **12E**. The package may also be used with the nearly identical structure of FIG. **13F**. Referring to FIG. **14A**, after overcoating the entire device with an insulating layer **97**, such as SiNx for example, access holes **120**, **122**, and **124** are formed using known etching/photomasking techniques to expose the top-most metal layers **60M'**, **60M''**, and **60M'''**, for the blue, green, and red LED (organic light emitting diode) devices, respectively, in this example. Thereafter, suitable metal circuit paths **126**, **128**, and **130** (typically of gold material), are deposited in a path from the exposed metal layers **60M'**, **60M''**, and **60M'''**, respectively, to edge located indium solder bumps **132**, **133**, and **134**, respectively, using conventional processing steps. Similarly, an anode electrode termination is provided via the metal (Au, for example) circuit path **135** formed to have an inner end contacting ITO layer **52**, and an outer end terminating at an edge located indium solder bump **136**, all provided via conventional processing. The device is then overcoated with additional insulating material such as SiNx to form an insulated covering with solder bumps **132**, **133**, **134**, and **136** being exposed along one edge. In this manner, the organic LED device can be readily packaged using conventional techniques, or the packaging embodiment of the invention as described immediately below.

A method for making four multicolor LED devices on a common substrate **50** in a packaged configuration will now be described, with reference to FIGS. **14A**, **14B**, and **14C**, respectively, for another embodiment of the invention. The starting material includes a glass substrate **50** coated with an overlayer of indium tin oxide (ITO) **52**. The following steps are used to obtain the packaged multicolor organic LED array:

1. Mask ITO layer **52** to deposit an SiO₂ layer **138** in a concentric square band ring pattern, in this example (some other pattern can be employed), on top of ITO layer **52** using conventional techniques.
2. Form four three-color LED stacks sharing common layers in region **140** on the ITO layer **52** using methods as taught above for obtaining, for example, either of the structures of FIGS. **12E** or **13F**, and **14A**.
3. Deposit via shadow masking metal contacts **170** through **181**; each terminating at exterior ends on SiO₂ layer **138**, for providing external electrical connecting or bonding pads **170'** through **181'**, respectively. Note that contacts **126**, **128**, and **130** in FIG. **14A** are the same as every successive three of contacts **170–181**, respectively. Each group of three contacts, namely **170** through **172**, **173** through **175**, **176** through **178**, and **179** through **181**, terminate at their interior or other ends to provide an electrical connection with the metal layers **60M'**, **60M''**, **60M'''**, respectively, of each of the four organic LED devices, respectively. Another metal contact **182** is deposited via shadow masking on an edge of ITO layer **52** common to all four of the LED devices, for providing a common anode connection, in this example. Note that if through appropriate masking and etching the four LED devices are made in completely independent layers, four anode contacts, respectively, will have to be provided for the latter array so that it can be operated in a multiplexed manner.

15

The multicolor LED array being described in this example is a non-multiplexed array.

4. Deposit via shadow masking using an "L" shaped mask in two steps or via photolithography, for example, a second SiO₂ layer **184** in a continuous band or ring leaving exposed bonding pads **170'** through **181'**, using either sputtering, or plasma enhanced CVD, or electron beam deposition, for example.
5. Deposit Pb-Sn or other low temperature melting solder in a continuous band or ring **186** on top of the second SiO₂ layer or band **184**.
6. Deposit on the bottom of a cover glass **188** a metal ring **190** to be coincident with the solder seal ring **186**.
7. Place the assembly in an inert gas atmosphere, such as dry nitrogen, and apply heat to melt solder ring **186** to obtain an air tight seal, with the inert gas trapped in interior region **192**.
8. Install cover glass **188** over the assembly, as shown in FIG. **14B**, with metal ring **190** abutting against the solder ring **186**.

Referring to FIG. **15**, there is shown a display **194** which is an RGB organic LED display. The dots **195** are ellipsis. A complete display as **194** comprises a plurality of pixels such as **196**. The pixels are arranged as a XY matrix to cover the entire surface area of a glass sheet coated with ITO. Each pixel includes a stacked LED structure as that shown in FIG. **2**. Instead of having fixed bias means as batteries **30**, **31** and **32** (FIG. **2**) each of the lines of terminals designated in FIG. **2** as blue (B), green (G) and red (R) are brought out and coupled to suitable horizontal and vertical scan processors **197** and **198**, respectively, all under control of a display generator **199** which may be a TV unit. Accordingly, each matrix of LEDs has at least two axes (x,y), and each LED is at the intersection of at least two of the axes. Also, the x-axis may represent a horizontal axis, and the y-axis a vertical axis. It is well known how to convert television signals such as the NTSC signals into the color components R, G and B for color displays. Monitors for computers which utilize red, green and blue for primary colors are also well known. The drive and control of such devices by vertical and horizontal scanning techniques are also known. The entire array of pixel structures deposited over the surface of the display is scanned employing typical XY scanning techniques as using XY addressing. These techniques are used in active matrix displays.

One can use pulse width modulation to selectively energize the red, green and blue inputs of each of the DH LED pixels according to desired signal content. In this manner, each of the LEDs in each line of the display are selectively accessed and addressed and are biased by many means such as by pulse width modulation signals or by staircase generated voltages to enable these devices to emit single colors or multiple colors, so that light emitted from said structures creates an image having a predetermined shape and color. Also, one can serially scan each of the xy axes, and serially energize selected ones of the LEDs in the matrix to emit light for producing an image with colors created serially vertically. Selected ones of the LEDs may be simultaneously energized.

As indicated above, the vertical layering technique shown in FIG. **2** allows the fabrication of the three color DH LED pixel within extremely small areas. This allows one to provide high definition displays such as displays that have 300 to 600 lines per inch resolution or greater. Such high resolution would be considerably more difficult to obtain using prior art techniques in which the organic emission

16

layers or fluorescent media generating the different colors are laterally spaced from one another.

Based on modern standards one can provide a LED device as shown in FIG. **2** with an effective area small enough to enable hundreds of pixel diodes to be stacked vertically and horizontally within the area of a square inch. Therefore, the fabrication techniques enables one to achieve extremely high resolution with high light intensity.

In FIG. **16**, another embodiment of the invention is shown for a multicolor LED device including the stacking of up to N individual LEDs, where N is an integer number 1,2, 3 . . . N. Depending upon the state of the technology at any future time, N will have a practical limit. The stacked N levels of LEDs can, for example, be provided using either the shadow masking process steps previously described for FIGS. **12** (A-E), or the dry etching process illustrated in FIGS. **13A** through **13F**. The base or bottom portion of the stacked array of FIG. **16** is a glass substrate **102** as shown in FIG. **13F**, for example, with an ITO layer **101** formed over substrate **102**. The immediately overlying first LED device, and following LED devices in this example, each include in succession over ITO layer **101** an HTL layer **154**, an EL layer **156**, an ETL layer **158**, a metal layer **160**, and an ITO layer **162**. The Nth level LED device **164** further includes a topmost metal layer (see layer **152** of FIG. **13F**) formed over the uppermost ITO layer **162** thereof. A passivation layer **119** is deposited over the stack, as in the color stack of FIG. **13F**. The material for each EL layer **156** of each LED device is selected for providing a particular color for the associated LED. As in the three color device, shorter wavelength (blue) devices must lie lower in the stack than the longer wavelength (red) devices to avoid optical absorption by the red emitting layers. The color selected for each respective LED and the actual number of stacked LEDs are dependent upon the particular application, and the desired colors and shading capability to be provided. Such multi-color devices can also be used in optical communications networks, where each different optical channel is transmitted using a different wavelength emitted from a given device in the stack. The inherently concentric nature of the emitted light allows for coupling of several wavelengths into a single optical transmission fiber. In practical such stacked arrays, access holes are formed down to the ITO layer **162** of each device followed by the deposition of appropriate metallization for facilitating packaging and electrical connection to each of the LED devices in the stack, in a manner similar to that described for the stacked multicolor LED device of FIGS. **14A**, **14B**, and **14C**, for example.

This device can be used to provide a low cost, high resolution, high brightness full color, flat panel display of any size. This widens the scope of this invention to displays as small as a few millimeters to the size of a building, but to a practical limit. The images created on the display could be text or illustrations in full color, in any resolution depending on the size of the individual LEDs.

The inventors recognized that if the multicolor organic LEDs, as described above relative to the description of FIGS. **1A** through **16**, are improved to be substantially fully transparent to a user when the OLED devices are de-energized, then such transparent organic light emitting devices (hereinafter TOLED) are directly applicable for use in heads-up displays, and other applications. For purposes of this description; heads-up displays are substantially transparent to a user when de-energized, thereby providing view through capability to the user. When a given one or more of the devices are energized, to emit light in this example, the effected portion of the display would then illuminate an

individual or multicolor display via the above-described organic LEDs incorporating the below-described embodiment of the invention. In order to accomplish this, the present inventors conceived methods and apparatus for overcoming the difficulties involved in the prior art in depositing transparent electrical contacts on soft material such as used in organic light emitting devices (OLEDs) without causing damage to the underlying layers, as typically occurs when using known prior processes. The inventors recognize that in overcoming these problems, OLED devices can then be used in heads-up displays that employ a variety of other display technologies, which themselves would benefit from the below-described embodiments of the invention for producing contacts that are substantially transparent to a user. For example, applications that may benefit from the present invention are heads-up displays employed in visors on a motorcyclist helmet, or a jet fighter pilots helmet, each patterned with OLEDs for providing direct view displays for gauges, maps, itinerary, and so forth. Other applications employing such OLED heads-up based displays may also include displays on windshields, teleprompters, and so forth. Video game displays and other type displays may also include OLED's of the present invention. Accordingly, the embodiments of the invention described below are believed to represent a significant step forward in the state-of-art.

Methods are known for depositing transparent contacts on hard material, or materials that are unaffected by temperatures exceeding about 50° C., such as silicon (Si) used in inorganic solarcells, for example. It should be noted that although the intended benefit of the below-described embodiment of the invention is for use in forming transparent contacts on soft material such as organic layers, the method and apparatus can also be used for depositing transparent contacts on hard materials.

It should be noted that the embodiments of the invention for providing OLED(s) as described above relative to the parent application U.S. Ser. No. 08/354,674, provide devices that have a luminescence band that is substantially red shifted from the absorption band by as much as 0.5 eV (electron volt). As a result, the present OLED(s) are highly transparent over their own emission spectrum and throughout most of the visible spectrum, thereby providing a property not found in inorganic semiconductor light emitters. Through use of the embodiments of the invention as described below for providing substantially transparent contacts, the present inventors have discovered a new class of vacuum-deposited organic luminescence devices which are greater than 71% transparent when de-energized, and are capable of emitting light from top and bottom diode surfaces with high efficiency when energized (approaching or exceeding 1% quantum efficiency).

To accomplish the above-described results, the first problem to be overcome by the inventors was to discover a metal capable of forming a good chemical bond with an underlying organic layer, to provide mechanical stability. It was determined that one such metal can be provided through the use of a metal alloy film of magnesium (Mg) and silver (Ag). However, other metals and/or metal alloy films such as fluorine doped tin oxides, Ca, In, Al, Sm, Y, Yb, MgAl, and various alloys containing these materials other than metal alloy films of Mg:Ag may be applicable for use (see Tang et al. U.S. Pat. No. 5,294,870). Films of Mg—Ag are presently considered to represent a preferred embodiment for the present invention. If the contact consists of a single metal, the metal must have a low work function. When the contact consists of a metal alloy, at least one of the metals must have

a low work function. In using Mg:Ag, Mg has a low work function. Also, the chosen metal must insure a good electrical bond with the organic layer, as determined through experimentation with various materials. The good electrical bond ensures the metal contact or electrode will inject a sufficient number of carriers into the organic layer.

After solving the first problem of establishing a metal or metal alloy for providing both a good chemical bond and electrical contact with an underlying organic layer, the next problem for the inventors was to determine how to make the contact transparent while preserving these other properties such as low electrical resistance. It was known that by making the metal layer very thin, a desired transparency for the layer could be obtained. However, the inventors recognized that the layer must be thick enough to protect the underlying organic layer from the required next processing step, in this example, of depositing an indium tin oxide (ITO) layer on top of the metal layer. Also, for example, a thin Mg layer oxidizes quickly, and must be coated with ITO as soon after being formed as possible to protect the Mg layer. Prior processes for doing this are conducted at high temperature and high power deposition, which would damage the underlying organic layer. Accordingly, the inventors conceived a process for depositing the ITO layer on the metal layer at very low power and room temperature, typically 22C (72F).

The ITO layer, in addition to being transparent, is also electrically conductive, and therefore reduces the electrical resistance of the multilayer contact formed with the Mg—Ag. The ITO cannot be used by itself for it typically does not provide a good bond with organic material (i.e. it does not stick well to organic material), and typically it is not a good electron injector into the organic electroluminescent material. The Mg:Ag layer, in this example, does provide a good bond to the organic layer and to the ITO, and is a good electron injector.

In FIG. 17, a cross-sectional view of an engineering prototype produced by the inventors for providing a transparent organic light emitting device (TOLED) is shown. In this example, device **300** is grown on a glass substrate **302** pre-coated with a transparent indium tin oxide (ITO) thin film **304** with a sheet resistivity of typically 20Ω(ohms)/square, depending on the thickness of the ITO film. Note that although substrate **302** consists of transparent glass, in this example, it can also be provided by any other transparent rigid support on which ITO can be coated, such as plastic material, for example. Also, the ITO film can be replaced by any suitable electrical conducting oxide or a conductive transparent polymer. Prior to deposition of the organic films, the substrate **302** was pre-cleaned using conventional techniques. Deposition was performed by sublimation, in a vacuum of 10^{-6} Torr, of a 200 Å thick layer **306** of the hole conducting compound N,N'-diphenyl-N,N'bis(3-methylphenyl)-1-1'biphenyl-4,4'diamine (TPD), followed by a 400 Å thick layer **308** of the electron conducting and highly electroluminescent Alq₃ (aluminum tris 8-hydroxyquinoline). A top layer **310** providing an electron-injecting contact to the device **300** was made-by deposition through a shadow mask (not shown) of a thin (50 Å–400 Å) semi-transparent Mg—Ag alloy electrode (in an approximate atomic ratio of 40Mg:1Ag), for example. Other atomic ratios, such as 50Mg:1Ag, can be used, depending upon the application, but note that the invention is not meant to be limited to any particular ratio or contact metal composition. Finally, the TOLED device **300** is capped by a second 400 Å thick ITO layer **312**, sputter-deposited onto the Mg—Ag surface of layer **310**. This second ITO layer **312** provides a

continuous, transparent conducting surface on top of which a second TOLED can be grown (see above for description of FIGS. 12, 13, and 16). ITO layer 312 is made as thick as possible to reduce resistivity, while retaining acceptable transparency. Electrical contacts 314 (negative polarity) and 316 (positive polarity) are bonded to ITO layers 312 and 304, respectively, using conventional processing.

The output of the device 300 measured from both the top and substrate device surfaces for a TOLED with a 100 Å thick Mg—Ag electrode 310, in this example, is shown in FIG. 18. Typical operating conditions for such TOLED devices 1 mm in diameter are 10^{-4} A (ampere) and 10V (volts) drive voltage (applied across terminals 314 and 316). The emission spectra from both surfaces are similar to conventional Alq₃-based devices described previously (C. W. Tang and S. A. VanSlyke, *Appl. Phys. Lett.*, Vol. 51, 913 (1987); and P. E. Burrows and S. R. Forrest, *Appl. Phys. Lett.*, Vol. 64, 2285 (1993)), although there is a slight (10 nm) shift of the emission toward the red of the light emerging from the top contact relative to the back contact. This may result from differences in the absorption spectrum of the Mg—Ag as compared to the ITO films, and/or absorption due to interfacial states in the Mg—Ag/ITO electrode. The total internal quantum efficiency of light emission from this device 300 example is 0.75%, which is comparable to the efficiency of conventional Alq₃-based OLEDs. Approximately 10% higher intensity is emitted through the substrate 302 than from the top contact 312.

The transparency as a function of wavelength of the TOLED 300 with a 100 Å thick film 310 is shown in detail in FIG. 19. At the short wavelength edge of the plot, the device becomes non-transmissive due to a combination of ITO absorption, Mg—Ag absorption, and the strong molecular transitions to the L_a and B_b states of Alq₃. Note, however, that the device is 63% transparent at the peak (530 nm) emission wavelength of Alq₃, and this transparency extends across the visible red. Some loss is apparent in the infrared, also due to absorption by the Mg—Ag top contact. FIG. 20 shows the transmission of the Mg—Ag contact 310 at a wavelength of 530 nm with Mg—Ag film 310 thicknesses ranging from 50 Å to 400 Å. Transparencies of 92% were observed for the thinnest Mg—Ag films. The thinnest working TOLED device produced thus far by the inventors has a Mg—Ag contact 310 thickness of 75 Å, corresponding to a contact transparency of 81%, and a total device transparency of 71%. The slope of the straight line fit to the data of FIG. 20 gives an optical absorption coefficient of the Mg—Ag of 1.1×10^6 cm⁻¹, which is consistent with a calculated skin depth of 180 Å.

Note that while the prototype TOLED devices described above emit in the green spectral region, the structure demonstrated should work equally well for organic devices emitting in any region of the visible spectrum, since the large Franck-Condon red shift from absorption to emission is characteristic of many organic materials. Using simple fabrication processes, it is therefore possible to construct an independently addressable stack of multi-color emissive elements. Furthermore, this structure should also be useful for polymer-based OLEDs, as previously indicated. For example, Mg:Ag alloy thin film layers with an overlying ITO layer are similarly described above for use as layers 26M and 26 of the OLED devices of FIGS. 2A, 2B and 2C, for providing improved transparent contacts 26; and for layers 60M and 60I of FIGS. 12B, 12C, 12D, 12E, and layers 107M and 107I of FIGS. 13A, 13B, 13C, 13D, 13E, and 13F, for providing improved transparent contacts 60, and 107, respectively. Similarly, Mg—Ag layers 310 with overlying

ITO layers 312 can be used in place of metal of metal layers 60M', 60M", and 60M''' of the OLED device of FIG. 14A, and metal layers 160 of the OLED device of FIG. 16. In this manner, viable TOLED multicolor devices are attainable.

The method and apparatus for placing transparent contacts onto organic material layers, whether for organic light emitting devices, or other devices, will now be described. In this example, the first step is to deposit a thin film of Mg:Ag alloy in some preferred ratio, such as 40:1, respectively, on top of a target organic layer, using thermal co-evaporation of constituent metal atoms from resistively heated molybdenum boats, in this example. As previously illustrated with reference to FIG. 20, the thickness of the metal alloy film is dominant in determining the transparency of the resultant contact. A system or apparatus for accomplishing this is shown schematically in FIG. 21. Note that in the following description of the evaporation system, and of other systems of the invention, the actual components used by the inventors in this example are given in a parts list presented below, along with a following manufactures index for providing the names and addresses of the manufacturers supplying the components illustrated.

The evaporation system for depositing the Mg:Ag film on an organic substrate, as shown in FIG. 21, will now be described in detail.

Mg:Ag film evaporation is performed in a vacuum chamber (E1) with a base pressure of about 10_{-7} Torr, that is maintained by an Alcatel 150 1/sec turbo pump (E2) in conjunction with Alcatel roughing pump (E3) and a cold trap (E4). Ag and Mg source metals are loaded into molybdenum (Mo) boats (E5) which are resistively heated by 10 kW (E6) and 1 kW (E7) power supplies to evaporate or vaporize the Mg:Ag in this example. The substrate (ES) is positioned 30 cm(d₁) above the Mo boats (E5) and is held in place by a water-cooled non-rotating substrate holder (E9). A shutter (E10), positioned in the path between the Mo boats (E5) and the substrate (E8), can be remotely and selectively operated to be in the open or closed position to respectively enable or block Mg:Ag evaporated-film deposition on the substrate (E8) by Mg:Ag vapor. Note that in a preferred deposition system the single shutter (E10) is replaced by two shutters (E10A, E10B, not shown) for independently blocking or enabling vapor flow of Mg and Ag, respectively, from an associated boat (E5) to substrate (E8). The thickness of the deposited film is measured by a film thickness monitor (E11) located next to the substrate. Two more thickness monitors (E12, E13) are located one above each of the Mo boats (E5), respectively, in order to provide independent measurements for the evaporation rates from the two boats.

The system of FIG. 21, as described, is operated using the following steps to deposit the Mg:Ag film of this example on a substrate (E8):

Position the shutter (E10) in the closed position.

Pump the evaporation chamber (E1) until it reaches 1×10^{-6} Torr (preferred, but can range 10^{-3} Torr to 10^{-10} Torr).

Turn on the 10 kW power supply (E6) and increase its power output slowly until Ag starts to melt.

Set Ag density and acoustic impedance parameters on the substrate-film thickness monitor (E11).

Set the output of the 10 kW power supply (E6) so that deposition rate of Ag, as registered by the substrate thickness monitor (E11), is 0.1 Å/s, in this example, but can be as high as 5 Å/s. Note the rate (R1) registered by Ag thickness monitor (E12).

Maintain R1 constant throughout the deposition process by adjusting the output of 10 kW power supply (E6), as required.

Set Mg parameters on the substrate-film thickness monitor (E11).

Set the output of the 1 kW power supply (E7) so that deposition rate of Mg, as registered by the substrate thickness monitor (E11), is 5 Å/s, which in this example is preferred but can otherwise range 0.1 Å/s to 10 Å/s. Note the rate (R2) registered by Mg thickness monitor (E13).

Maintain R2 constant throughout the deposition process, by adjusting the output of 1 kW power supply (E7), as required.

Mount the substrate (E8) onto the substrate holder (E9). Position the shutter (E10) in the open position.

Deposit ~100 Å of Mg:Ag alloy, which is preferred in this example, but can otherwise range 50 Å to 500 Å.

After the Mg:Ag alloy film is deposited on substrate (E8). The substrate is transferred from the thermal evaporation chamber (E1), via a load lock chamber (S4), (see FIG. 22), to a sputtering chamber (S1) of an RF sputtering system. During this transfer, the sample is kept in vacuum, or inert atmosphere such as nitrogen or argon gas atmosphere, through use of the load lock chamber (S4), in this example.

Next, an indium-tin oxide (ITO) film is deposited on top of the Mg:Ag metal alloy film by RF sputtering in chamber (S1). Resistivity of this ITO film is 1.5×10^{-3} Ωcm. In this example, the ITO film is 400 Å thick.

The sputtering system, as shown in FIG. 23, in this example, is housed in a high vacuum chamber (S1) with a base pressure ranging between 1×10^{-3} Torr to 1×10^{-10} Torr (lower base pressure is preferred to reduce interaction with ambient gases), that is maintained by CTI-Cryogenics Cryo-Torr 8 cryo pump (S2). Attached to this chamber via gate valve (S3) is a load-lock chamber (S4) with base pressure ranging from atmospheric to 1×10^{-10} Torr (lower base pressure is preferred), that is maintained by Leybold Turbovac 50 turbo pump (S5). Through the load-lock chamber (S4) samples are introduced into the sputtering system and extracted out at completion of deposition. In this example, the sputtering target (S6), manufactured by Pure Tech., Inc. is 10% SnO₂ and 90% In₂O₃ by weight, with 99% purity. Target (S6) has a diameter of two inches with a thickness of one-eighth of an inch. A copper backing plate (S17), one-eighth inch thick, is attached by vacuum epoxy to the back of the target (S6) to prevent target (S6) from overheating and cracking. The target (S6) is housed in an AJA International magnetron sputtering gun (S7), powered by advanced Energy RF Power supply (S8) (with 600 W maximum RF power output, and operating frequency of 13.56 MHz) in conjunction with Advanced Energy auto-tunable impedance matching network (S9). Any RF power supply that provides at least 20 W RF power is sufficient. A shutter (S10), positioned over the sputtering gun (S7) and the target (S6), can be selectively positioned in the open or closed position to respectively enable or prevent sputtered-film deposition on the substrate (S11). The substrate (S11) is positioned 15 cm(d_z) above the shuttered target (S6) and is held in place by a water-cooled non-rotating substrate holder (S12). Note that d_z can preferably range from 5 cm to 30 cm, but can be greater. The thickness of the deposited film is measured by a calibrated film thickness monitor (S13) located next to the substrate (S11). The sputtering gas is a mix of argon (Ar) (99.9999% pure) and oxygen (O₂) (99.998% pure). The flow of gasses into the sputtering chamber (S1) is controlled by individual MKS mass flow controllers (S14). The gas pressure inside the sputtering chamber (S1) is monitored by an MKS Baratron type 121A absolute pressure transducer (S15)

and controlled by a butterfly valve (S16) positioned in front of the cryo pump (S2).

The sputtering system of FIG. 23 is operated to deposit an ITO layer on top of the Mg:Ag film using the following operational steps:

Remove the sample from vacuum chamber (E1).

Introduce the sample into the load lock chamber (S4).

Pump down the load lock chamber until it reaches its base pressure.

Transfer the sample into the sputtering chamber (S4) and position it over the sputtering target (S6).

Position the target shutter (S10) in the closed position.

Set argon (Ar) gas flow into the sputtering chamber at a preferred rate of 200 sccm (can range 20 sccm to 1,000 sccm depending upon the system pumping speed), and oxygen (O₂) flow preferably at 0.1 sccm (can range 0.0 sccm to 100 sccm dependent upon both the Argon gas flow rate and the sputtering power, where greater flow of O₂ is required for higher sputtering power).

Set the butterfly valve (S16) to maintain the chamber pressure of 20 mTorr, preferred in this example, or as low as 1 mTorr, but must be sufficient to allow for ignition of the plasma, and to sustain the plasma.

Set the RF power supply (S8) to an output power between 15 W to 30 W and enable it. When the auto-tuned impedance matching network (S9) finds the optimal setting the plasma should ignite.

Reduce the pressure inside the sputtering chamber (S1) to 5 mTorr by setting the butterfly valve (S16), in order to sustain the plasma as the power is decreased in the next step.

Slowly reduce the output power on the RF power supply (S8) equal to or less than 5 W, making sure impedance matching network (S9) has enough time to respond to the change.

Position the target shutter (S10) in the open position.

Deposit between 50 Å to 600 Å of ITO, dependent upon the desired balance between transparency of the ITO layer, and its electrical conductivity.

Note that an important embodiment of the invention is the use of low RF power (5 W or less) in sputtering ITO to deposit a thin film of ITO onto the Mg:Ag layer in this example, to avoid damaging the underlying organic layer. The RF power can be reduced to below 5 W by using different gas mixtures in the sputtering chamber, such as 1 Xe:10Ar, or 1 CH₃:20Ar, to further avoid damaging the organic layer while maintaining the growth rate for the ITO film. It is preferred that the RF power in the sputtering chamber be slowly reduced to the minimum wattage for sustaining ignition of the plasma.

A parts list, as given below in Table 1, for reference designations (E1) through (E13), for the deposition system of FIG. 21, and (S1) through (S17), for the sputtering system of FIG. 23, lists the description, part or model number, and associated manufacturer. Table 1 is followed by a manufacturer's index listing, providing the identified manufacturer's names in full along with their last known address and telephone numbers. It should be noted that the invention is not meant to be limited to use of the illustrated components and parts, and manufacturers, and is provided herein only to fully illustrate apparatus employed by the inventors in developing their invention through experimental engineering prototypes.

TABLE 1

ITEM #	ITEM DESCRIPTION	MODEL #	MANUF.
E1	Vacuum Chamber	DV-502A	Denton
E2	150 1/s Turbo Pump	CFE-450 Turbo	Alcatel
E3	Mechanical Roughing Pump	20008A	Alcatel
E4	Liquid Nitrogen Cold Trap	standard	Denton
E5	Molybdenum Source Boats	standard	Mathis
E6	10 kW Power Supply	standard	Denton
E7	1 kW Power Supply	standard	Denton
E8	User Provided Substrate	—	—
E9	Water Cooled Substrate Holder	custom	Denton
E10	Shutter	standard	Denton
E11	Film Thickness Monitor	STM-100/MF	Sycon
E12	Film Thickness Monitor	STM-100/MF	Sycon
E13	Film Thickness Monitor	STM-100/MF	Sycon
S1	Vacuum Chamber	—	DCA Inst.
S2	Cryogenic Pump	Cryo-Torr 8	CTI
S3	Gate Valve (6 inch diameter)	GC-4000M	MDC
S4	Load Lock Chamber (6 in., 6 way cross)	custom	MDC
S5	Turbo Pump	Turbovac 50	Leybold
S6	10% SnO ₂ , 90% In ₂ O ₃ target (2 in. diam.)	with Cu backplate (S17)	Pure Tech
S7	RF Magnetron Sputtering Gun	—	AJA Intern.
S8	600 W 13.56 MHz RF Power Supply	RFX-600	Adv. Energy
S9	Impedance Matching Network	AIX-600	Adv. Energy
S10	Integral part of S7	—	AJA Intern.
S11	User Provided Substrate	custom	—
S12	Water Cooled Substrate Holder	custom	DCA Inst.
S13	Film Thickness Monitor	STM-100/MF	Sycon
S14	Mass Flow Controllers	1259C	MKS
S15	Absolute Pressure Transducer	Baratron #121A	MKS
S16	Butterfly Valve	L6691-301	Varian
S17	Cu Backplate	Epoxied to (S6)	Pure Tech

Manufacturer Index

- Adv. Energy
 - Advanced Energy Industries, Inc.
 - 1600 Prospect Parkway, Fort Collins, Colo. 80525 (303) 221-4670
- AJA Intern,
 - AJA International
 - North Scituate, Mass. 02060 (800) 767-3698
- Alcatel
 - Alcatel Vacuum Products, Inc.
 - Hingham, Mass. 02043 (617) 331-4200
- CTI
 - CTI-Cryogenics
 - Mansfield, Mass. 02048 (508) 337-5000
- DCA Inst.
 - DCA Instruments, Inc.
 - 400 West Cummings Park, Suite 3900, Woburn, Mass. 01801 (617) 937-6550

- Denton
 - Denton Vacuum, Inc.
 - Moorestown, N.J. 08057 (609) 439-9100
- 5 Leybold
 - Leybold Vacuum Products, Inc.
 - Export, Pa. 15632 (800) 443-4021
- Mathis
 - R.D. Mathis Co.
 - 2840 Gundry Ave., P.O. Box 6187, Long Beach, Calif. 90806 310 426-7049
- MDC
 - MDC Vacuum Products Corp.
 - 15 Hayward, Calif. 94545 (510) 887-6100
- MKS
 - MKS
 - 6 Shattuck Rd., Andover, Mass. 01810 (508) 975-2350
- 20 Pure Tech
 - Pure Tech, Inc.
 - Carmel, N.Y. 10512 (914) 878-4499
- Sycon
 - 25 Sycon Instruments
 - 6757 Kinne St., East Syracuse, N.Y. 13057 (315) 463-5297
- Varian
 - 30 Varian Vacuum Products
 - Lexington, Mass. 02173 (800) 8-VARIAN.
- In another embodiment of the invention for growing the ITO layer 312 onto the Mg:Ag film 310, in this example (see FIG. 17), it was recently discovered that the ITO growth rate can be increased by growing the first 50–100 Å by the non-destructive (slow) method given above, followed by stepping up the rate to make the contact 312 thicker (typically 400–1000 Å using higher power settings for RF power supply (S8) (20 W–40 W, for example). Since there is already a protective cap of 50–100 Å grown at lower power settings for (S8) (1 W–7 W, for example), this second, quickly grown ITO layer does not have the ability to penetrate the first ITO slow-grown contact and destroy the underlying Mg:Ag and organic layers 310, 308, respectively.
 - 45 It was also discovered that Alq₃ and related compounds for the organic layers are very immune to this damage, whereas the blue compounds are vulnerable. As a result the inventors now put in a “double heterostructure” (see FIG. 1A), e.g. first the TPD 306, then a blue emitter material layer ranging in thickness between 50 Å to 1,000 Å, followed by a layer of Alq₃, ranging in thickness from 300 Å to 1,000 Å. The resultant TOLED device still luminesces blue.
- Those with skill in the art may recognize various modifications to the embodiments of the invention described and illustrated herein. Such modifications are meant to be covered by the spirit and scope of the appended claims. For example, a multicolor stacked LED device, such as the above-described three color device of FIG. 2, in another embodiment of the invention can be provided by forming
 - 60 LED 20 from a polymer device as shown in FIG. 1C, or from a deposited metal phosphonate film, rather than having all three layers laid down in vacuo. The two remaining stacked LEDs could be formed by vapor deposition, or other techniques. Also, the Mg:Ag alloy can range from 1Mg:1Ag to
 - 65 40Mg:1Ag to 100% Mg with proper chemistry. In yet another embodiment the ITO layers for the TOLED device can be formed by presputtering, spraying, or dipping.

What is claimed is:

1. A method of fabricating an organic light emitting device structure, comprising:
 - obtaining a substrate coated with a first electrically conductive layer, wherein the first electrically conductive layer has a positive polarity;
 - fabricating a transparent organic light emitting device over said first electrically conductive layer;
 - depositing a transparent electrically conductive metal layer having a thickness less than about 100 angstroms over the transparent organic light emitting device; and
 - depositing a second electrically conductive layer over the transparent electrically conductive metal layer, wherein the second electrically conductive layer has a negative polarity, and wherein the second electrically conductive layer is selected from the group consisting of a transparent electrically conductive oxide layer and a transparent electrically conductive polymer layer.
2. The method of claim 1 wherein the second electrically conductive layer comprises a transparent electrically conductive oxide layer.
3. The method of claim 1 wherein the second electrically conductive layer comprises indium tin oxide.
4. The method of claim 3 wherein the step of depositing said indium tin oxide over the transparent electrically conductive metal layer comprises:
 - (1) forming a protective cap layer comprising indium tin oxide over said transparent electrically conductive metal layer using a non-destructive growth rate; and then
 - (2) increasing the growth rate for depositing indium tin oxide on said protective cap layer.
5. The method of claim 4 wherein said protective cap layer has a thickness of about 50 to about 100 angstroms.
6. The method of claim 3 wherein the substrate is transparent.
7. The method of claim 3 wherein the substrate is rigid.
8. The method of claim 3 wherein the first electrically conductive layer is transparent.
9. The method of claim 3 wherein the first electrically conductive layer comprises indium tin oxide.
10. The method of claim 3 wherein the first electrically conductive layer comprises a reflective metal layer.
11. The method of claim 3 wherein the obtaining step comprises coating said substrate with said first electrically conductive layer.
12. The method of claim 1 wherein the transparent electrically conductive metal layer comprises magnesium.
13. The method of claim 12 wherein the transparent electrically conductive metal layer further comprises silver.
14. A method of fabricating an organic light emitting device structure, comprising:
 - obtaining a substrate coated with a first electrically conductive layer, wherein the first electrically conductive layer has a positive polarity;
 - fabricating a transparent organic light emitting device over said first electrically conductive layer;
 - depositing a transparent electrically conductive metal layer having a thickness less than about 100 angstroms over the transparent organic light emitting device, wherein the transparent electrically conductive metal layer comprises magnesium and silver; and
 - depositing an indium tin oxide layer over the transparent electrically conductive metal layer, wherein the indium tin oxide layer has a negative polarity.

15. The method of claim 14 wherein the step of depositing said indium tin oxide layer over the transparent electrically conductive metal layer comprises:
 - (1) forming a protective cap layer comprising indium tin oxide over said transparent electrically conductive metal layer using a non-destructive growth rate; and then
 - (2) increasing the growth rate for depositing indium tin oxide on said protective cap layer.
16. The method of claim 15 wherein said protective cap layer has a thickness of about 50 to about 100 angstroms.
17. The method of claim 15 wherein the substrate is transparent.
18. The method of claim 15 wherein the substrate is rigid.
19. The method of claim 15 wherein the first electrically conductive layer comprises indium tin oxide.
20. The method of claim 15 wherein the first electrically conductive layer comprises a reflective metal layer.
21. The method of claim 15 wherein the obtaining step comprises coating said substrate with said first electrically conductive layer.
22. The method of claim 14 wherein the first electrically conductive layer is transparent.
23. A method of fabricating an organic light emitting device structure, comprising:
 - obtaining a substrate coated with a first electrically conductive layer, wherein the first electrically conductive layer has a positive polarity;
 - depositing a hole transporting layer over the first electrically conductive layer;
 - depositing an electron transporting layer over the hole transporting layer;
 - depositing a transparent electrically conductive metal layer over the electron transporting layer, wherein the metal has a work function less than about 4 eV; and
 - depositing a second electrically conductive layer over the transparent electrically conductive metal layer, wherein the second electrically conductive layer has a negative polarity, and wherein the second electrically conductive layer is selected from the group consisting of a transparent electrically conductive oxide layer and a transparent electrically conductive polymer layer.
24. The method of claim 23 wherein the method further comprises the step of depositing an emission layer over the hole transporting layer and then depositing the electron transporting layer over the emission layer.
25. The method of claim 23 wherein the second electrically conductive layer comprises a transparent electrically conductive oxide layer.
26. The method of claim 23 wherein the second electrically conductive layer comprises indium tin oxide.
27. The method of claim 26 wherein the step of depositing the indium tin oxide over the transparent electrically conductive metal layer comprises:
 - (1) forming a protective cap layer comprising indium tin oxide over the transparent electrically conductive metal layer using a non-destructive growth rate; and then
 - (2) increasing the growth rate for depositing indium tin oxide on the protective cap layer.
28. The method of claim 27 wherein the protective cap layer has a thickness of about 50 to about 100 angstroms.
29. The method of claim 26 wherein the substrate is transparent.
30. The method of claim 26 wherein the substrate is rigid.
31. The method of claim 26 wherein the first electrically conductive layer is transparent.

32. The method of claim 26 wherein the first electrically conductive layer comprises indium tin oxide.

33. The method of claim 26 wherein the first electrically conductive layer comprises a metal layer.

34. The method of claim 26 wherein the obtaining step comprises coating said substrate with said first electrically conductive layer.

35. The method of claim 23 wherein the transparent electrically conductive metal layer comprises magnesium.

36. The method of claim 35 wherein the transparent electrically conductive metal layer further comprises silver.

37. The method of claim 26 wherein the transparent electrically conductive metal layer has a thickness less than 100 angstroms.

38. A method of fabricating an organic light emitting device structure, comprising:

obtaining a substrate coated with a first electrically conductive layer, wherein the first electrically conductive layer has a positive polarity;

depositing a hole transporting layer over the first electrically conductive layer;

depositing an electron transporting layer over the hole transporting layer;

depositing a layer comprising magnesium and silver over the electron transporting layer; and

depositing an indium tin oxide layer over the layer comprising magnesium and silver, wherein the indium tin oxide layer has a negative polarity.

39. The method of claim 38 wherein the method further comprises the step of depositing an emission layer over the hole transporting layer and then depositing the electron transporting layer over the emission layer.

40. The method of claim 38 wherein the step of depositing the indium tin oxide layer over the transparent electrically conductive metal layer comprises:

(1) forming a protective cap layer comprising indium tin oxide over the transparent electrically conductive metal layer using a non-destructive growth rate; and then

(2) increasing the growth rate for depositing indium tin oxide on the protective cap layer.

41. The method of claim 40 wherein the protective cap layer has a thickness of about 50 to about 100 angstroms.

42. The method of claim 38 wherein the substrate is transparent.

43. The method of claim 38 wherein the substrate is rigid.

44. The method of claim 38 wherein the first electrically conductive layer is transparent.

45. The method of claim 38 wherein the first electrically conductive layer comprises indium tin oxide.

46. The method of claim 38 wherein the first electrically conductive layer comprises a metal layer.

47. The method of claim 38 wherein the obtaining step comprises coating said substrate with said first electrically conductive layer.

48. The method of claim 38 wherein the layer comprising magnesium and silver has a thickness less than 100 angstroms.

49. A method of fabricating an organic light emitting device structure, comprising:

obtaining a substrate coated with a first electrically conductive layer, wherein the first electrically conductive layer has a positive polarity;

depositing a hole transporting layer over the first electrically conductive layer;

depositing an electron transporting layer over the hole transporting layer;

depositing a transparent electrically conductive metal layer over the electron transporting layer, wherein the transparent electrically conductive metal layer has a thickness less than about 100 angstroms; and

depositing a second electrically conductive layer over the transparent electrically conductive metal layer, wherein the second electrically conductive layer has a negative polarity, and wherein the second electrically conductive layer is selected from the group consisting of a transparent electrically conductive oxide layer and a transparent electrically conductive polymer layer.

50. The method of claim 49 wherein the method further comprises the step of depositing an emission layer over the hole transporting layer and then depositing the electron transporting layer over the emission layer.

51. The method of claim 49 wherein the second electrically conductive layer comprises a transparent electrically conductive oxide layer.

52. The method of claim 49 wherein the second electrically conductive layer comprises indium tin oxide.

53. The method of claim 52 wherein the step of depositing the indium tin oxide over the transparent electrically conductive metal layer comprises:

(1) forming a protective cap layer comprising indium tin oxide over the transparent electrically conductive metal layer using a non-destructive growth rate; and then

(2) increasing the growth rate for depositing indium tin oxide on the protective cap layer.

54. The method of claim 53 wherein the protective cap layer has a thickness of about 50 to about 100 angstroms.

55. The method of claim 49 wherein the transparent electrically conductive metal layer comprises magnesium.

56. The method of claim 55 wherein the transparent electrically conductive metal layer further comprises silver.

57. The method of claim 49 wherein the substrate is transparent.

58. The method of claim 49 wherein the substrate is rigid.

59. The method of claim 49 wherein the first electrically conductive layer is transparent.

60. The method of claim 49 wherein the first electrically conductive layer comprises indium tin oxide.

61. The method of claim 49 wherein the first electrically conductive layer comprises a metal layer.

62. The method of claim 49 wherein the obtaining step comprises coating said substrate with said first electrically conductive layer.

63. A method of fabricating an organic light emitting device structure, comprising:

obtaining a substrate coated with a first electrically conductive layer, wherein the first electrically conductive layer has a positive polarity;

fabricating a transparent organic light emitting device over said first electrically conductive layer;

depositing an electrically conductive metal layer having a thickness of 50 to 400 angstroms over the transparent organic light emitting device; and

depositing a transparent electrically conductive oxide layer over the electrically conductive metal layer, wherein the transparent electrically conductive oxide layer has a negative polarity.

64. The method of claim 63 wherein the transparent electrically conductive oxide layer comprises indium tin oxide.

29

65. The method of claim 63 wherein the step of depositing said indium tin oxide over the electrically conductive metal layer comprises:

- (1) forming a protective cap layer comprising indium tin oxide over said electrically conductive metal layer using a non-destructive growth rate; and then
- (2) increasing the growth rate for depositing indium tin oxide on said protective cap layer.

66. The method of claim 65 wherein said protective cap layer has a thickness of about 50 to about 100 angstroms.

67. The method of claim 63 wherein said electrically conductive metal layer has a thickness of about 50 to about 100 angstroms.

68. The method of claim 63 wherein the electrically conductive metal layer comprises magnesium.

69. The method of claim 68 wherein the electrically conductive metal layer further comprises silver.

70. The method of claim 63 wherein the substrate is transparent.

71. The method of claim 63 wherein the substrate is rigid.

72. The method of claim 63 wherein the first electrically conductive layer is transparent.

73. The method of claim 63 wherein the first electrically conductive layer comprises indium tin oxide.

74. The method of claim 63 wherein the first electrically conductive layer comprises a reflective metal layer.

75. The method of claim 63 wherein the obtaining step comprises coating said substrate with said first electrically conductive layer.

76. A method of fabricating an organic light emitting device structure, comprising:

obtaining a substrate coated with a first electrically conductive layer, wherein the first electrically conductive layer has a positive polarity;

depositing a hole transporting layer over the first electrically conductive layer;

depositing an electron transporting layer over the hole transporting layer;

depositing an electrically conductive metal layer having a thickness of 50 to 400 angstroms over the electron transporting layer; and

30

depositing a transparent electrically conductive oxide layer over the electrically conductive metal layer, wherein the transparent electrically conductive oxide layer has a negative polarity.

77. The method of claim 76 wherein the method further comprises the step of depositing an emission layer over the hole transporting layer and then depositing the electron transporting layer over the emission layer.

78. The method of claim 76 wherein the transparent electrically conductive oxide layer comprises indium tin oxide.

79. The method of claim 76 wherein the step of depositing said indium tin oxide over the electrically conductive metal layer comprises:

- (1) forming a protective cap layer comprising indium tin oxide over said electrically conductive metal layer using a non-destructive growth rate; and then
- (2) increasing the growth rate for depositing indium tin oxide on said protective cap layer.

80. The method of claim 79 wherein said protective cap layer has a thickness of about 50 to about 100 angstroms.

81. The method of claim 76 wherein said electrically conductive metal layer has a thickness of about 50 to about 100 angstroms.

82. The method of claim 76 wherein the electrically conductive metal layer comprises magnesium.

83. The method of claim 82 wherein the electrically conductive metal layer further comprises silver.

84. The method of claim 76 wherein the substrate is transparent.

85. The method of claim 76 wherein the substrate is rigid.

86. The method of claim 76 wherein the first electrically conductive layer is transparent.

87. The method of claim 76 wherein the first electrically conductive layer comprises indium tin oxide.

88. The method of claim 76 wherein the first electrically conductive layer comprises a reflective metal layer.

89. The method of claim 76 wherein the obtaining step comprises coating said substrate with said first electrically conductive layer.

* * * * *

UNITED STATES PATENT AND TRADEMARK OFFICE
CERTIFICATE OF CORRECTION

PATENT NO. : 6,596,134 B2
DATED : July 22, 2003
INVENTOR(S) : Forrest et al.

Page 1 of 1

It is certified that error appears in the above-identified patent and that said Letters Patent is hereby corrected as shown below:

Column 9,

Line 10, please delete “-hydroxyguinoline” and insert -- -hydroxyquinoline --;

Column 11,

Line 17, please delete “guinoline” and insert -- quinoline --;

Column 20,

Line 26, please delete “10.7” and insert -- 10^{-7} --;

Line 46, please delete “(E12), E13)” and insert -- (E12, E13) --;

Column 25,

Line 15, please delete “hasd” and insert -- has --;

Column 29,

Line 1, please delete “claim 63” and insert -- claim 64 --;

Column 30,

Line 12, please delete “claim 76” and insert -- claim 78 --.

Signed and Sealed this

First Day of June, 2004



JON W. DUDAS
Acting Director of the United States Patent and Trademark Office